



User Manual

Universal Video Recorder

1. Overview of UVR.....	5
1.1 Front Panel.....	5
1.2 Rear Panel.....	5
1.3 HDD Installation.....	7
1.4 Camera and Monitor Connection.....	8
1.5 Power Supply Connection.....	9
1.6 USB Mouse Operation.....	9
1.7 Input Method Description.....	10
2. Startup.....	12
2.1 Starting Up and Shutting Down the UVR.....	12
2.2 Using the Startup Wizard.....	14
2.3 Login and Logout.....	18
2.3.1 Set Unlock Pattern.....	18
2.3.2 Log in via Unlock Pattern.....	18
2.3.3 Log in via Password.....	19
2.3.4 User Logout.....	20
2.4 Adding Online IP Cameras.....	20
2.5 Editing the Connected IP Cameras and Configuration.....	24
3. Live View.....	25
3.1 Introduction of Live View.....	25
3.2 Operations in Live View Mode.....	26
3.3 Quick Setting Toolbar in Live View Mode.....	26
3.3.1 Coaxial Control from UVR.....	28
4. Playback.....	29
4.1 GUI Introduction.....	29
4.2 Normal Playback.....	30
4.3 Event Playback.....	33
4.4 Backup Clip.....	34
5.Backup.....	36
6. Configuration (Common Mode).....	37
6.1 System Settings.....	37
6.1.1 General Configuration.....	37
6.1.2 Account.....	38
6.2 Network Configuration.....	40
6.2.1 General - TCP/IP.....	40
6.2.2 P2P.....	41
6.2.3 Email.....	42
6.3 Camera Management.....	44
6.3.1 Network Camera.....	44
6.3.2 Event.....	50
6.3.3 Configure Alarm Trigger Process.....	53
7. Maintenance.....	55
7.1 System.....	55
7.2 Record.....	56

7.3 Hard Disk Operation.....	57
7.4 Network.....	58
7.5 Management.....	59
7.6 Log.....	60
7.7 User.....	61
7.7.1 Storage.....	62
7.7.2 Configure Recording Schedule.....	65
8. Alarm Center.....	69
8.1 Alarm Center.....	69
9. Configuration (Advanced Mode).....	70
9.1 System Settings.....	70
9.1.1 General Configuration.....	70
9.1.2 View Setting.....	71
9.1.3 Account.....	73
9.2 Network.....	75
9.2.1 IP Address.....	75
9.2.2 Platform Access.....	77
9.2.3 Advanced.....	77
9.2.4 Transfer.....	82
9.2.5 Wireless.....	84
9.3 Camera.....	86
9.3.1 Channel.....	86
9.3.2 Encode.....	92
9.3.3 Image Parameters.....	92
9.4 Normal Event.....	97
9.4.1 Motion Detection.....	97
9.4.2 Video Lost.....	97
9.4.3 Exception.....	98
9.5 Smart Event.....	99
9.6 Storage.....	99
9.6.1 Schedule.....	99
9.6.2 HDD Management.....	100
9.7 Backup.....	104
9.7.1 Backup.....	104
9.8 Playback.....	104
9.8.1 Normal Playback & Event Playback.....	104
9.8.2 Label Play.....	104
9.8.3 Smart Play.....	106
9.8.4 Time Division Play.....	111
9.8.5 Normal Play (Picture).....	112
10. Web Operation.....	113
10.1 Introduction.....	113
10.2 Login.....	113
10.3 Preview.....	114

10.4 Playback.....	115
10.5 Set.....	116
10.6 Log.....	116
11. Appendix.....	118
11.1 Glossary.....	118
Legal Information.....	119
About This Manual.....	119
Trademarks.....	119
Disclaimer.....	119
FCC Information.....	120
FCC Compliance.....	120
FCC Conditions.....	121
Safety Instructions.....	121
Preventive and Safety Guidelines.....	122

1. Overview of UVR

1.1 Front Panel

The UVR front panel is shown in Figure 1-1.

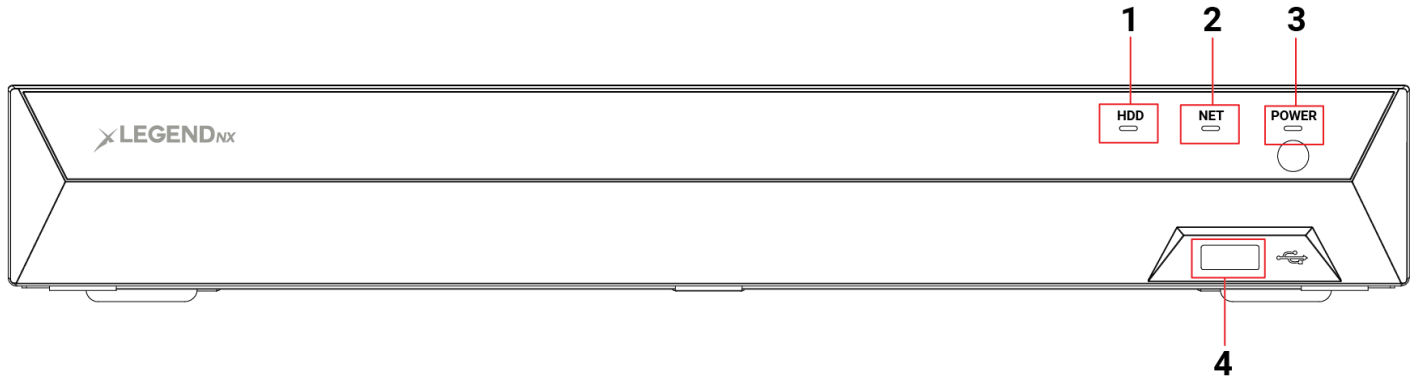

Figure 1-1 Front panel of UVR

Table 1-1 Description of the front panel

No.	Function Description
1	Hard disk status indicator
2	Network status indicator
3	Power status indicator
4	USB interface

Note

The drawings above are for reference only and may not represent the actual size or scale of the product.

1.2 Rear Panel

The UVR rear panel is shown in Figure 1-2, Figure 1-3, and Figure 1-4.

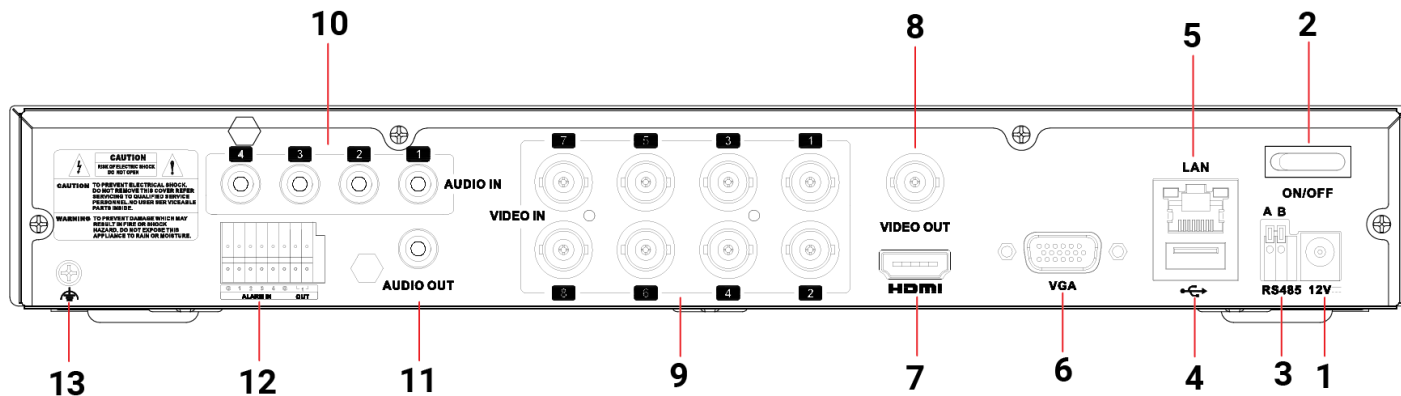

Figure 1-2 Rear Panel of the LGNX814KUVR

Table 1-2 Description of the LGNX814KUVR Rear Panel

No.	Function Description
1	Power Input
2	Power Switch
3	RS485 port
4	USB port
5	Network Port
6	VGA Port
7	HDMI Port
8	Video Output Port
9	Video Input Port
10	Video Input RCA
11	Video Output RCA
12	Alarm Input
13	Ground

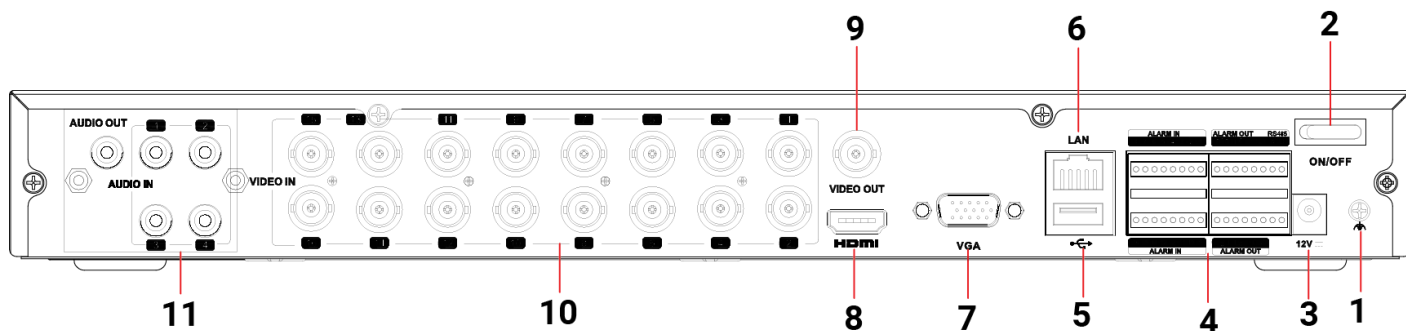

Figure 1-3 Rear Panel of the LGNX1624KUVR

Table 1-3 Description of the LGNX1624KUVR Rear Panel

No.	Function Description
1	Ground
2	Power Switch
3	Power Input
4	Alarm Input
5	USB Port
6	Network Port
7	VGA Port
8	HDMI Port
9	Video Output Port
10	Video Output RCA
11	Video Input RCA

1.3 HDD Installation

Before installing the hard disk drive (HDD), ensure that the UVR is powered off and disconnected from the power supply. For HDD capacity limits, refer to the UVR specifications. The UVR can still perform monitoring functions without an HDD; however, recording and playback will not be available.

If the HDD is installed correctly, the HDD indicator will blink regularly when the UVR is operating.

Ensure the power is turned off before installing the HDD. The installation images are for reference only.

Figure 1-4 Remove the cover



Figure 1-5 Secure the HDD



Figure 1-6 Connect the power and data cables



Figure 1-7 Reinstall the cover and screws



Note

- If higher HDD performance is required, it is strongly recommended to use a dedicated surveillance-grade hard drive.
- Do not remove the hard drive while the NVR is running.

1.4 Camera and Monitor Connection

Connect IP cameras to the UVR via network cables. Connect AHD cameras to the BNC ports on the UVR. For video output, connect a monitor using the HDMI or VGA port.

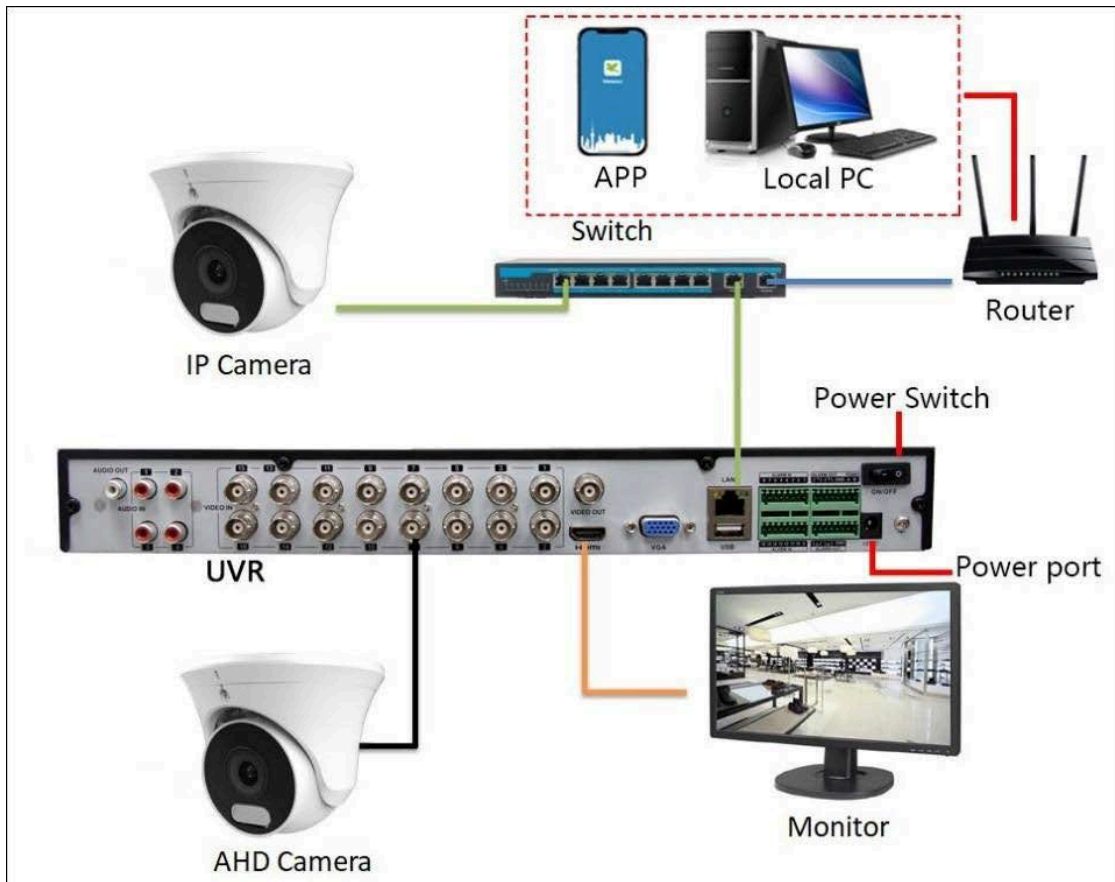

Figure 1-9 Device connection

1.5 Power Supply Connection

Use the supplied power adapter to connect the UVR. Before powering on the device, ensure that all cables connected to the video I/O ports and the network port are properly secured.

1.6 USB Mouse Operation

A standard 3-button (left/right/scroll wheel) USB mouse can be used with this UVR. To use a USB mouse:

1. Connect the USB mouse to one of the USB ports on the front panel of the UVR.
2. The mouse will be detected automatically. If the mouse is not detected, it may be due to compatibility issues. Refer to the recommended device list provided by your supplier.

Table 1-4 Key Functions of USB Mouse Operation

Items	Action	Description
Left-click	Single-click	Live view: Select channel. Quick menu: Select and confirm.
	Double-click	Live view: Switch between single-screen and multi-screen display.

	Click and drag	Live view: Drag channel. Playback: Adjust timeline. Alarm: Select target area. Digital zoom: Drag to select target area.
Right-click	Single-click	Live view: Open shortcut menu. Menu: Return to the previous menu.
Left & right click	Press simultaneously	Hold for 5 seconds to switch the device resolution to the lowest setting.
Scroll wheel	Scroll up	Menu: Increase the value of the selected setting.
	Scroll down	Menu: Decrease the value of the selected setting.

1.7 Input Method Description

The soft keyboard interface is shown in Figure 1-10, Figure 1-11, and Figure 1-12.



Figure 1-10 Soft keyboard (1)







Figure 1-11 Soft keyboard (2)



Figure 1-12 Soft keyboard (3)

Table 1-5 Description of the Soft Keyboard Icons

Button	Description
	Symbol input

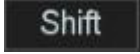
	Numeric input
	Confirm input
	Insert space
	English letters
	Delete previous character
	Switch between lowercase and uppercase

2. Startup

2.1 Starting Up and Shutting Down the UVR

Purpose

Proper startup and shutdown procedures are essential for extending the service life of the UVR.

Before you start

Ensure that the external power supply voltage meets the UVR requirements and that the grounding connection is functioning properly.

Starting up the UVR

Steps:

1. Ensure the power supply is connected to an electrical outlet. It is highly recommended to use an Uninterruptible Power Supply (UPS) with the device. The **Power** indicator on the front panel should be on, indicating that the device is receiving power.
2. Turn on the power switch on the rear panel if this is the first startup, or press the power button on the front panel (if available). The **Power** indicator should blink or remain steadily on, indicating that the device is starting.
3. After startup, a beep will be heard and the **Power** indicator will remain on. A startup screen displaying the HDD status will appear on the monitor. The row of icons at the bottom of the screen indicates the HDD status. An "X" indicates that the HDD is not installed or cannot be detected.

Shutting down the UVR

Steps:

1. Move the mouse to the bottom of the interface to open the menu, then access the shutdown options. Go to **Power > Shutdown**.

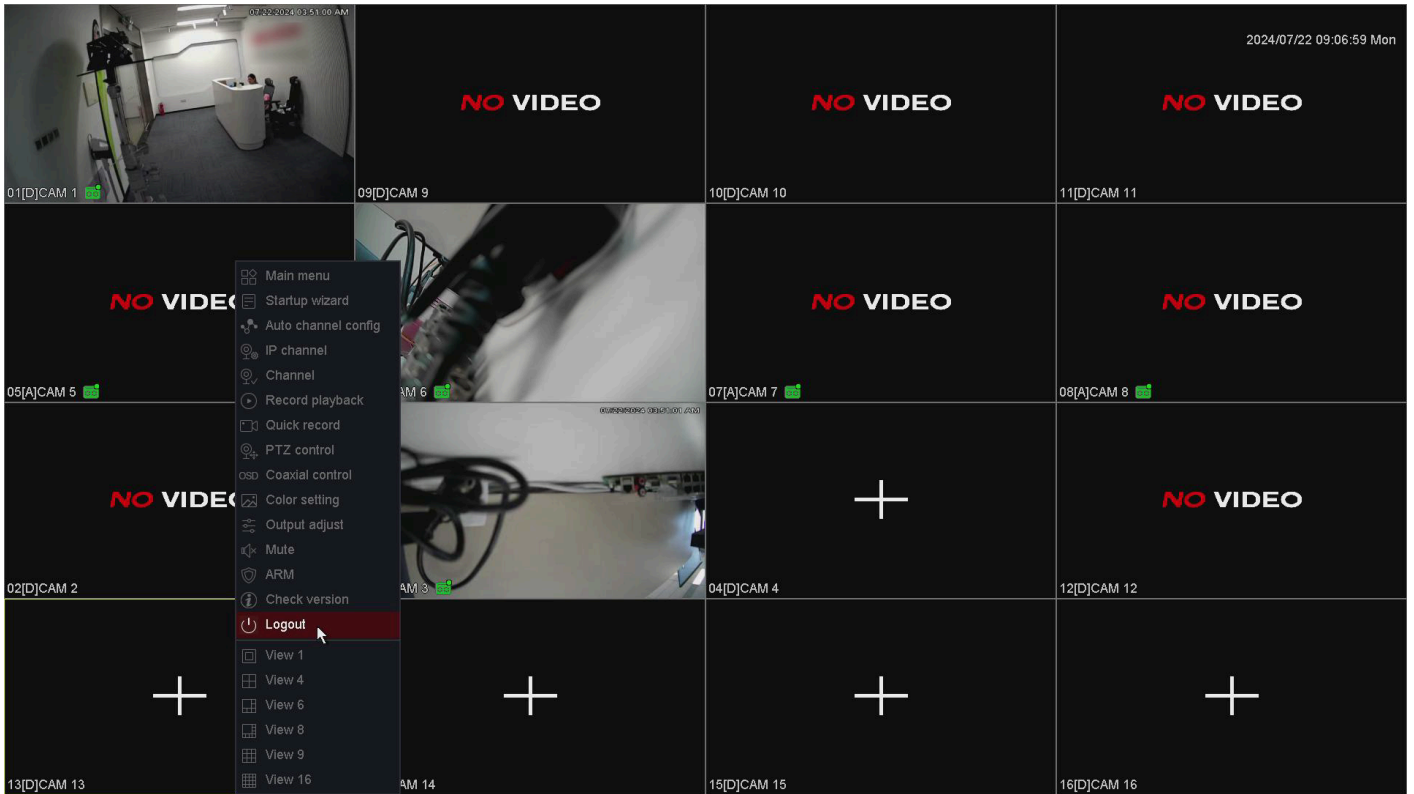

Figure 2-1 Power

2. Select Shutdown.

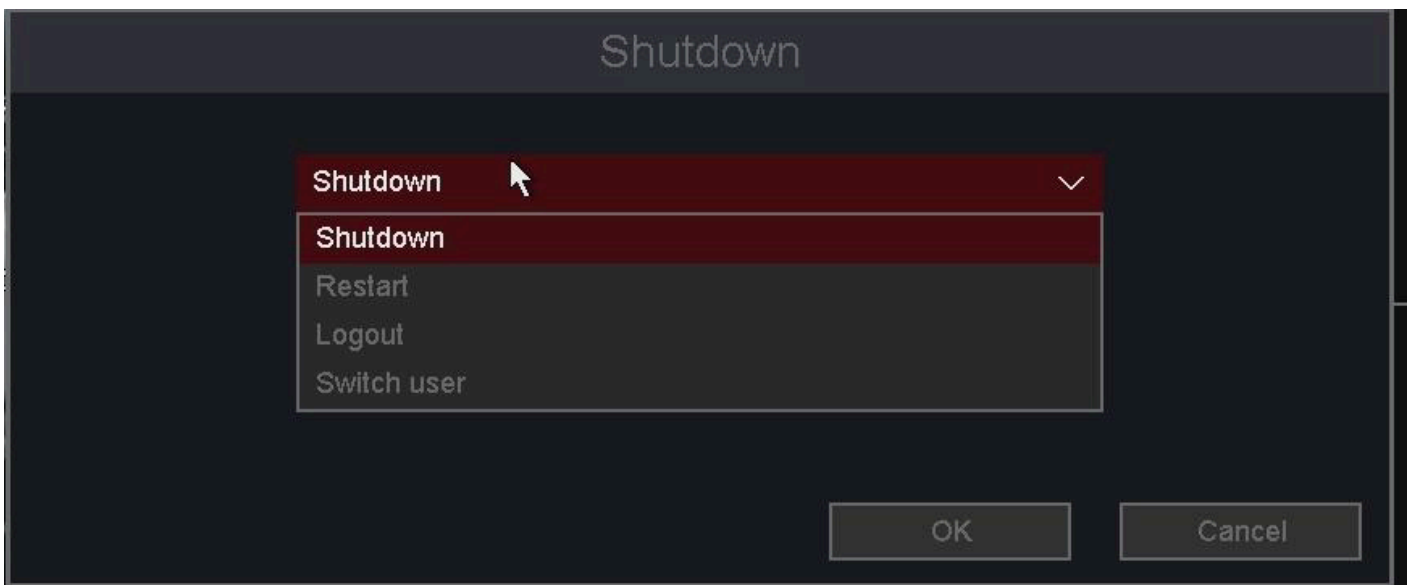

Figure 2-2 Shutdown Menu

Restarting the UVR

You can also restart the UVR from the Shutdown menu.

Steps:

1. Go to **Power**.
2. Select **Restart** to restart the UVR.

2.2 Using the Startup Wizard

Steps:

1. By default, the Startup Wizard launches automatically after the UVR starts.

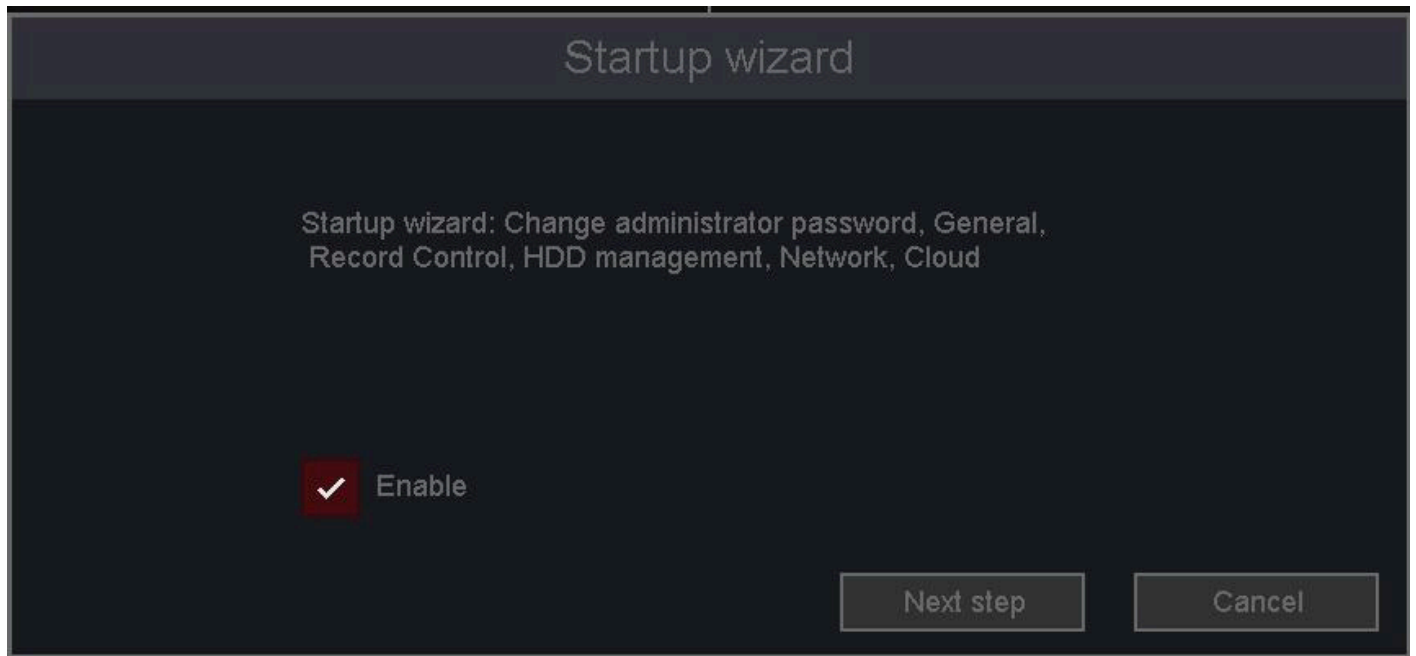

Figure 2-3 Startup Wizard

Note

The Startup Wizard guides you through important basic settings of the UVR. If you do not want to use the Startup Wizard at this time, click **Cancel**. To use it at the next startup, leave the **Enable** checkbox selected.

2. Click **Next Step** to open the administrator settings window.

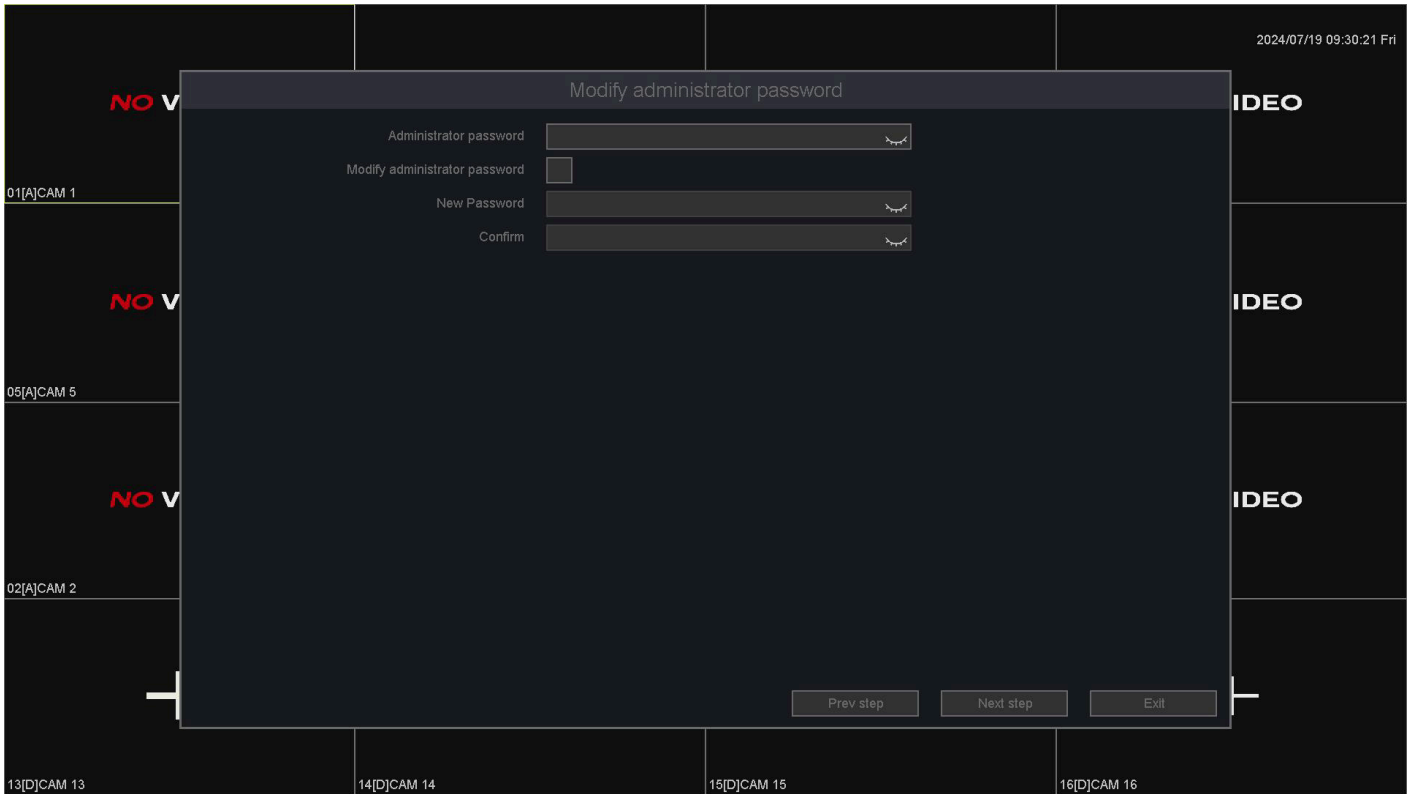

Figure 2-4 Modify administrator password

3. Click **Next Step** to open the general settings window.

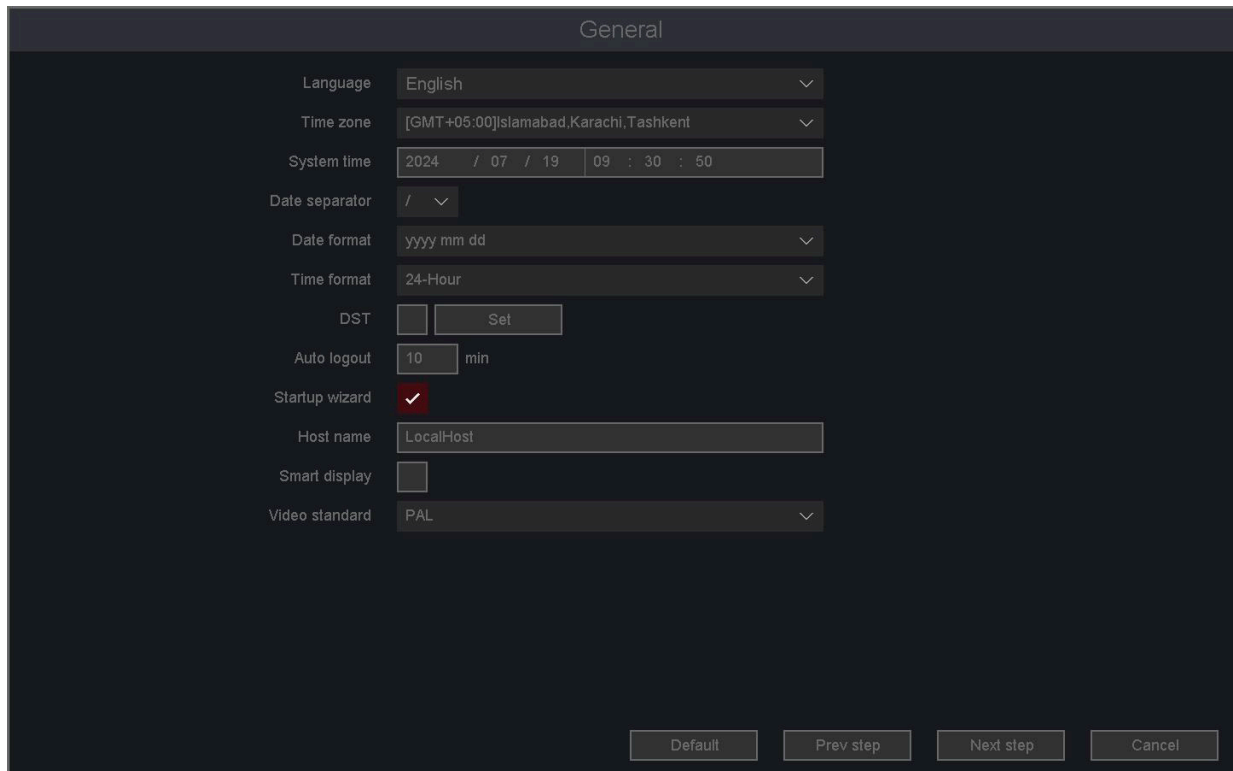

Figure 2-5 General

4. After completing the general settings, click **Next Step** to proceed to the control setup wizard.

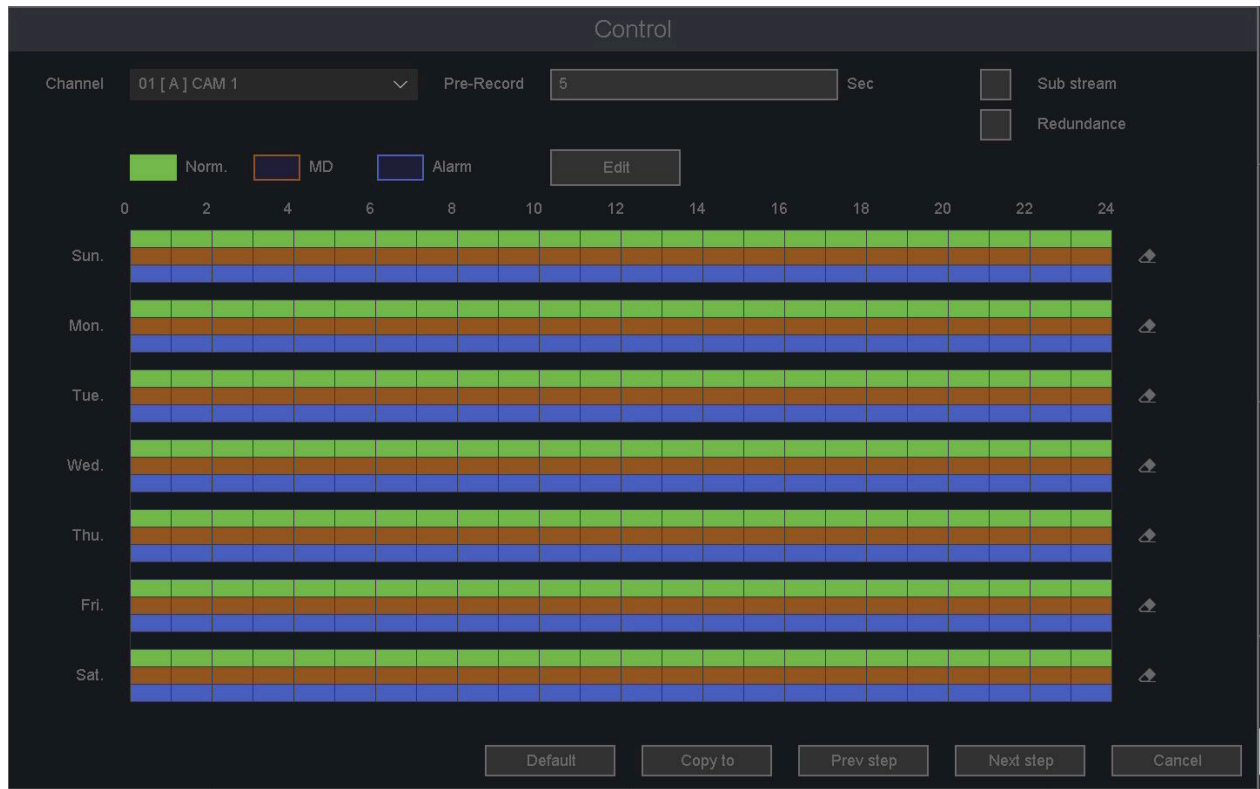

Figure 2-6 Record

5. After configuring the recording settings, click **Next Step** to open the HDD management window.

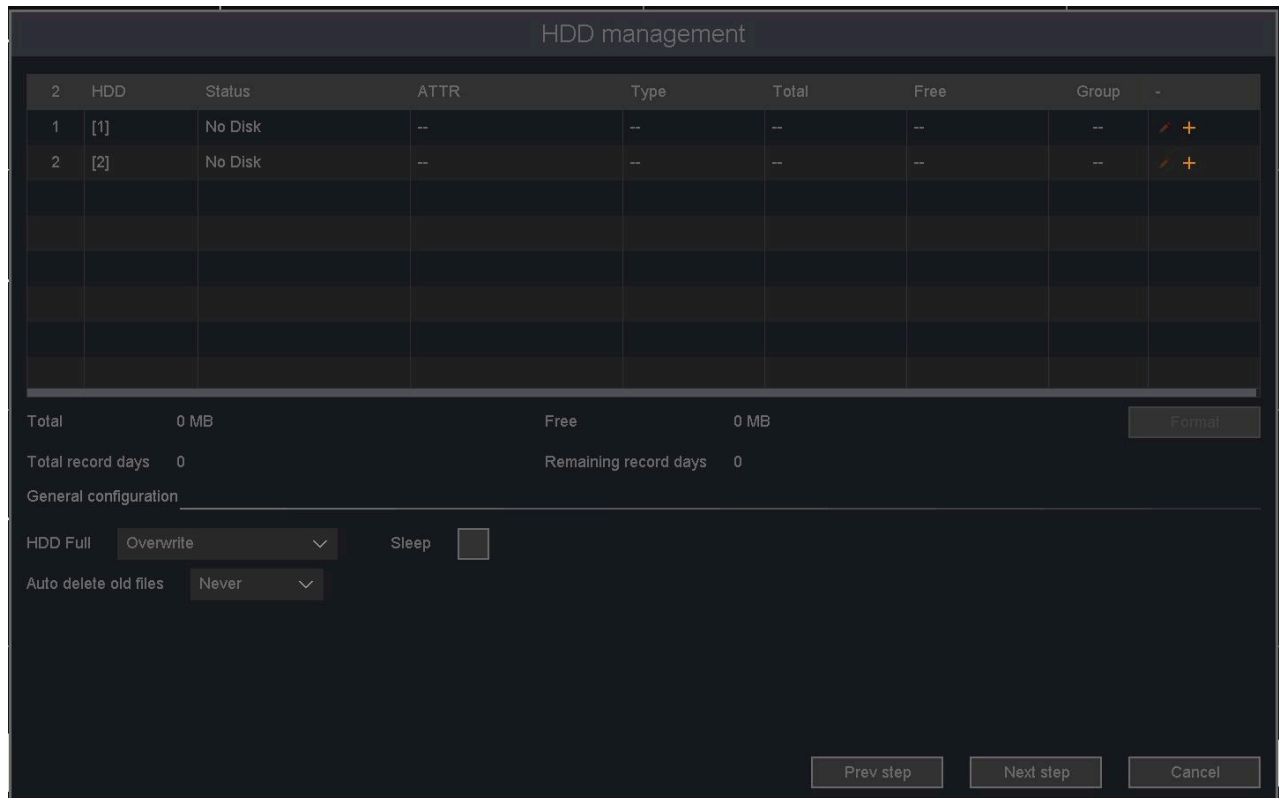

Figure 2-7 HDD Management

6. Click **Next Step** to enter the network setup wizard.

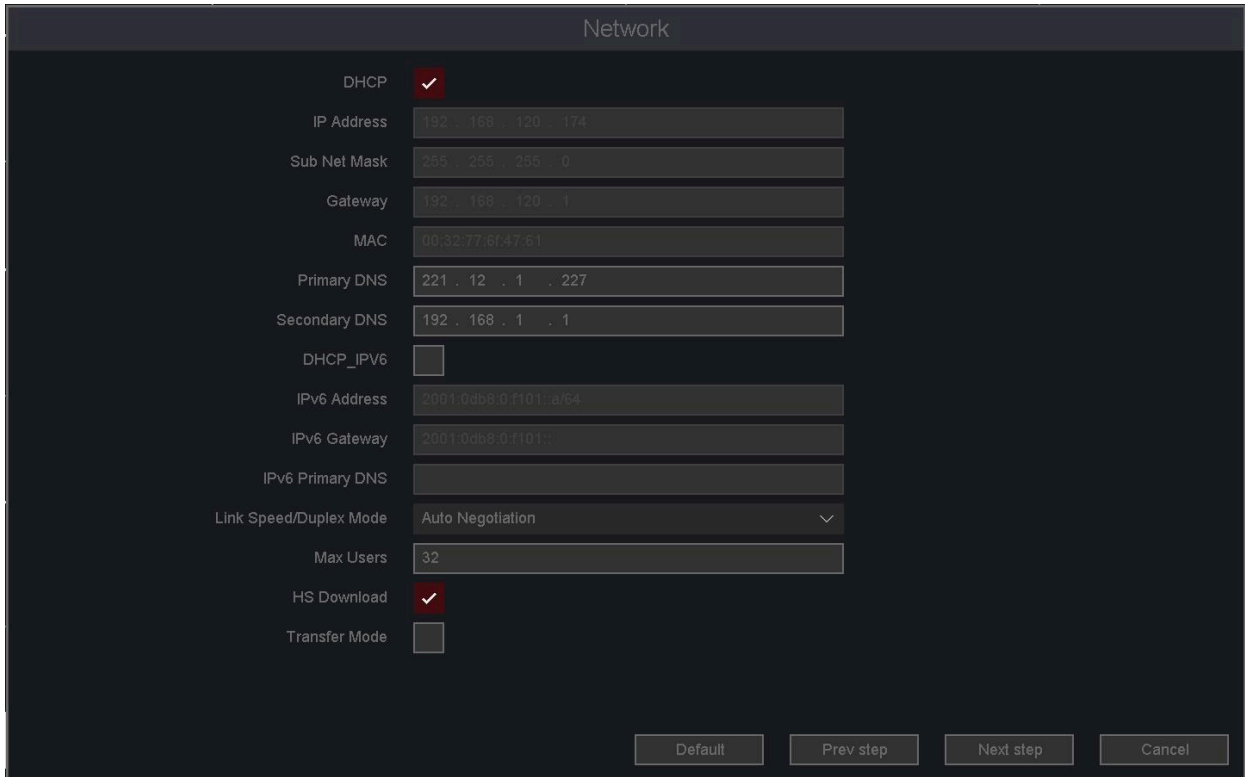

Figure 2-8 Network

7. After configuring the network parameters, click **Next Step** to open the cloud service setup wizard.

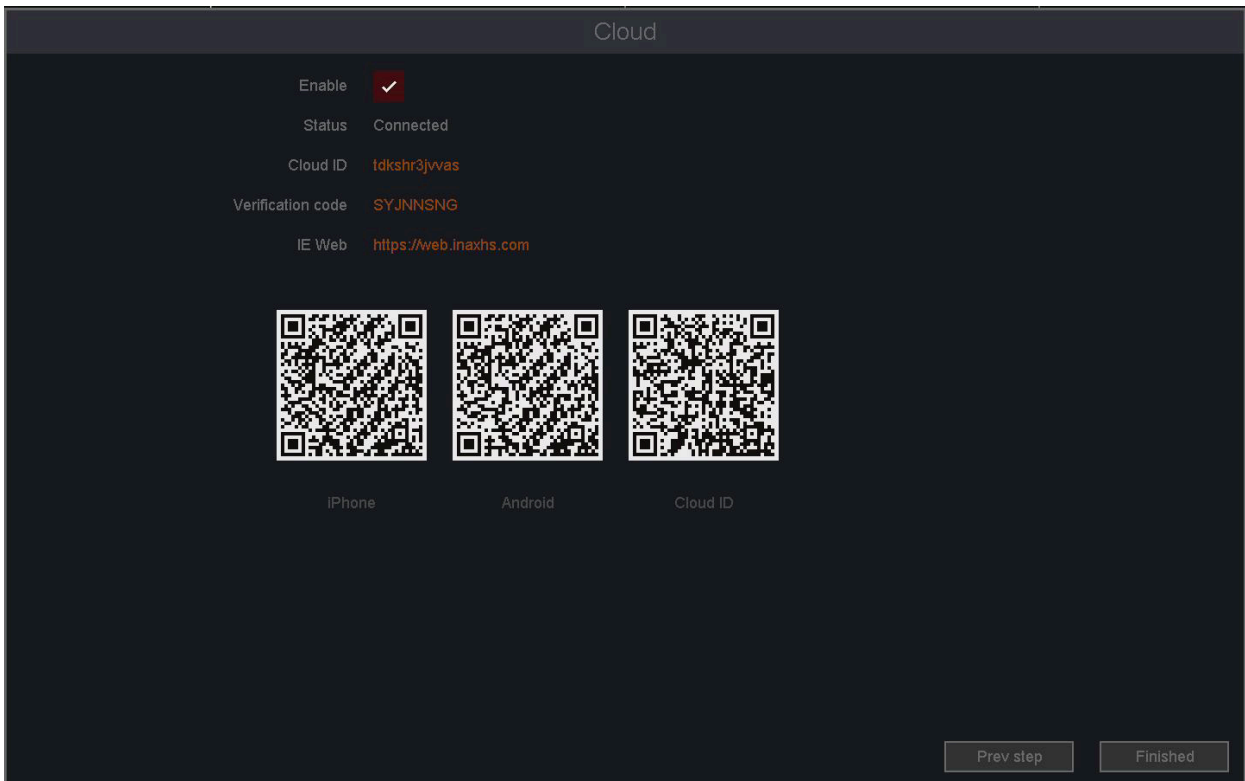

Figure 2-9 Cloud

8. Click **Finished**.

2.3 Login and Logout

2.3.1 Set Unlock Pattern

Administrator users can log in using an unlock pattern. You can set the unlock pattern during device activation. Alternatively, go to **Main Menu > System > Security > Account** to modify the password.

Steps:

1. Press and hold the mouse button, then draw a pattern connecting the 9 dots on the screen. Release the mouse button once the pattern is complete.

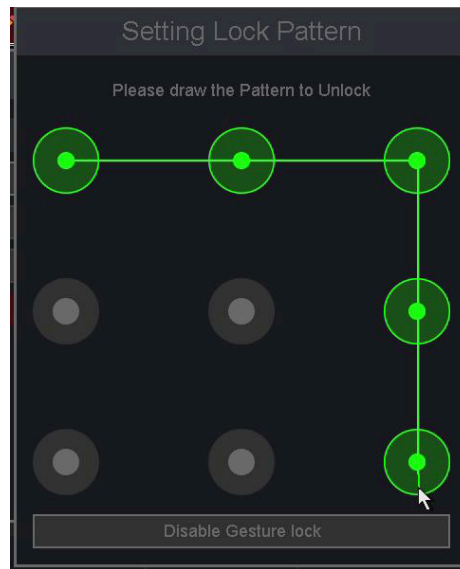

Figure 2-10 Set Unlock Pattern

Note

- The pattern must include at least 4 dots.
- Each dot can only be used once.

2. Draw the same pattern again to confirm. When the two patterns match, the pattern is successfully set.

2.3.2 Log in via Unlock Pattern

If a pattern password is set, it can be used for login when accessing menu operations (it is also required during the initial step of the startup wizard after reboot).

Steps:

1. Select the desired menu.
2. Draw the predefined pattern to unlock and access the menu.

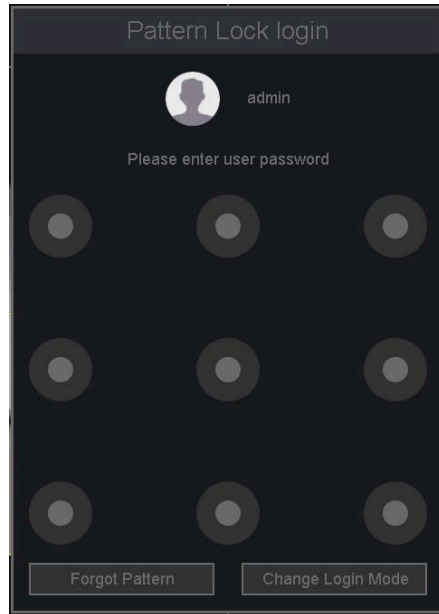

Figure 2-11 Draw the Unlock Pattern

Note

- If you forget the pattern, click **Forgot Pattern** or **Switch Login Mode** to log in using a password.
- If an incorrect pattern is entered more than 5 times, the system will lock the account for 30 minutes.

2.3.3 Log in via Password

If the video recorder has logged out, you must log in again to access the menu and other functions.

Steps:

1. Select **User Name**.

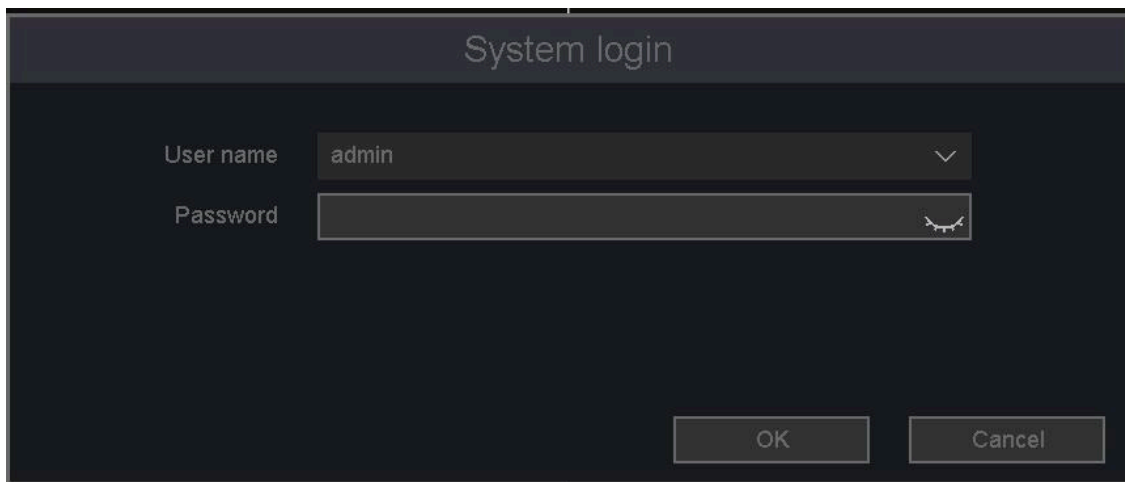

Figure 2-12 Login Interface

2. Enter the password.
3. Click **OK**.

Note

- The default username and password are **admin / 123456**.
- If you forget the administrator password, contact your installer to reset it.
- If an incorrect password is entered 5 times, the current user account will be locked for 30 minutes.

2.3.4 User Logout

After logging out, the device remains on the preview screen. To perform any operations other than live viewing, you must log in again using your account credentials.

Steps:

1. Right-click and select **Logout**.

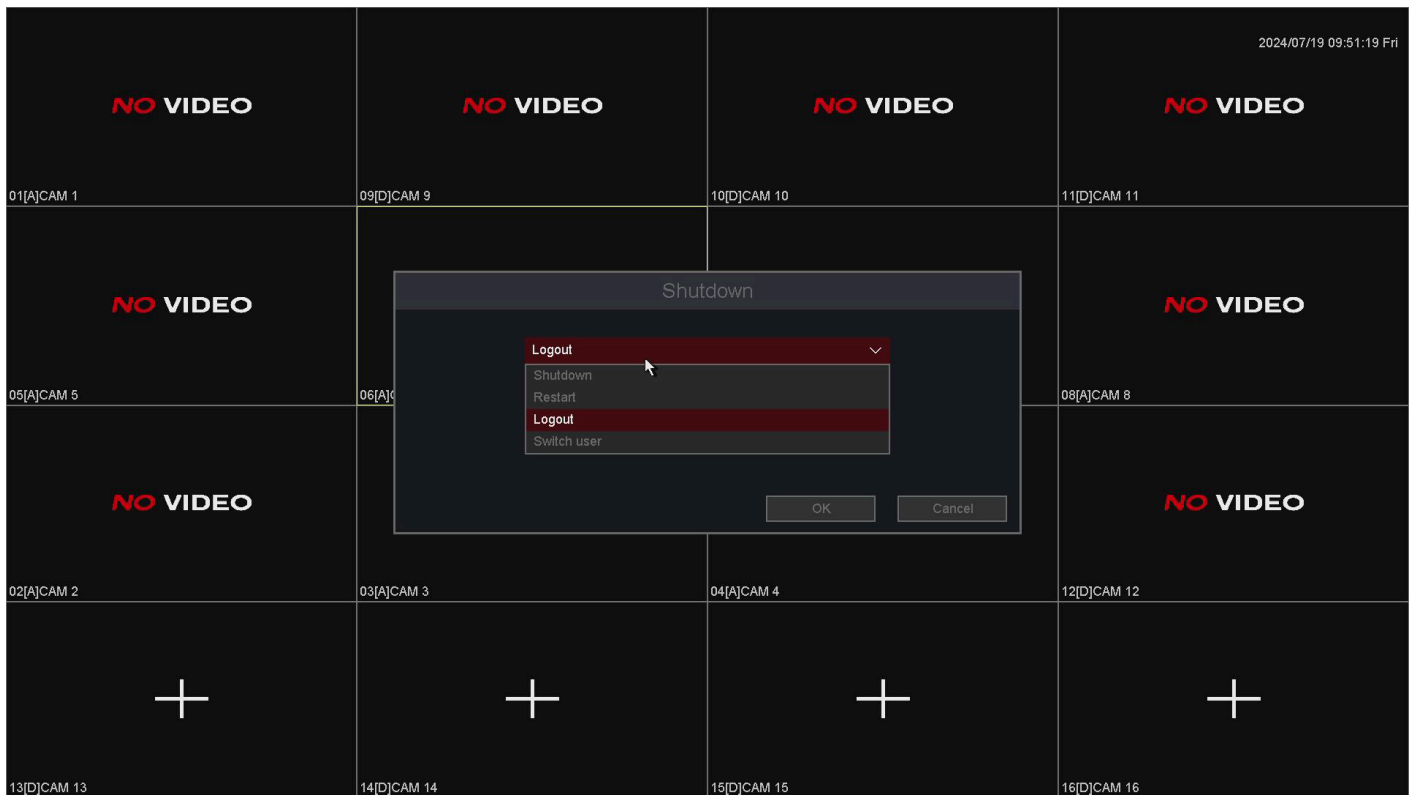

Figure 2-13 Logout

Note

After logging out of the system, the on-screen menu operation buttons will be disabled. You must log in again to unlock the system.

2.4 Adding Online IP Cameras

Power on the AHD camera and connect it to the BNC ports of the UVR. The video will be displayed automatically. You can also connect IP cameras through the local network by configuring the camera to be in the same IP range as the UVR.

Before you start:

Ensure that the network connection is available and properly configured. It is recommended to verify all settings before proceeding.

The UVR supports switching a certain number of analog channels to IP channels, depending on the model specifications.

Note

Channels 1–4 form one group, channels 5–8 form another group, and so on. For example, if channel 2 is switched from analog to IP mode, channels 1–4 will all switch to IP channels together.

Adding IP Cameras

Option 1:

Steps:

1. Go to **Main Menu > Channel > Channel Type**.
2. Select four consecutive channels and click **Apply**.

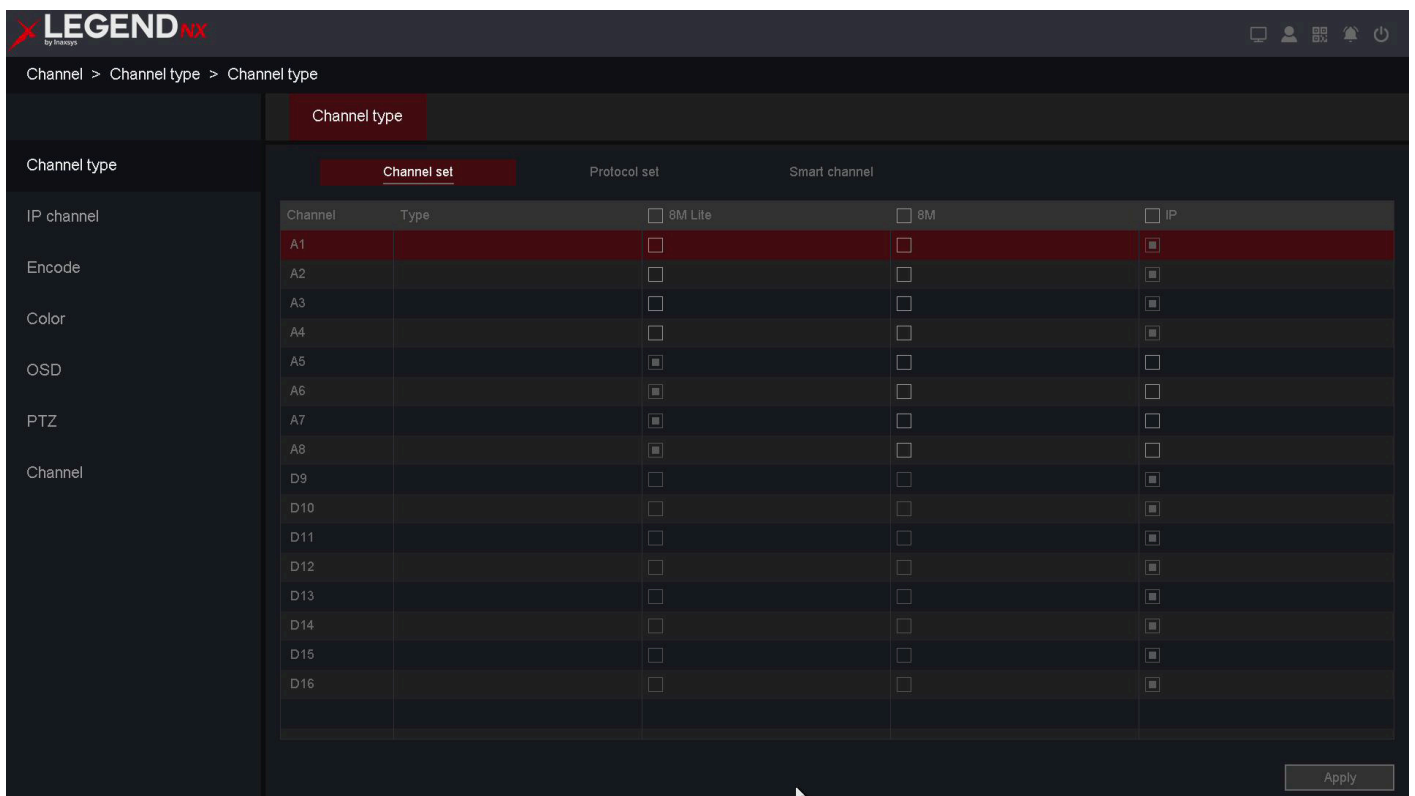

Figure 2-14 Select IP Channels

Note

Enabling additional IP channels will disable certain intelligent features.

3. Click **OK**, then wait for the device to complete the restart.

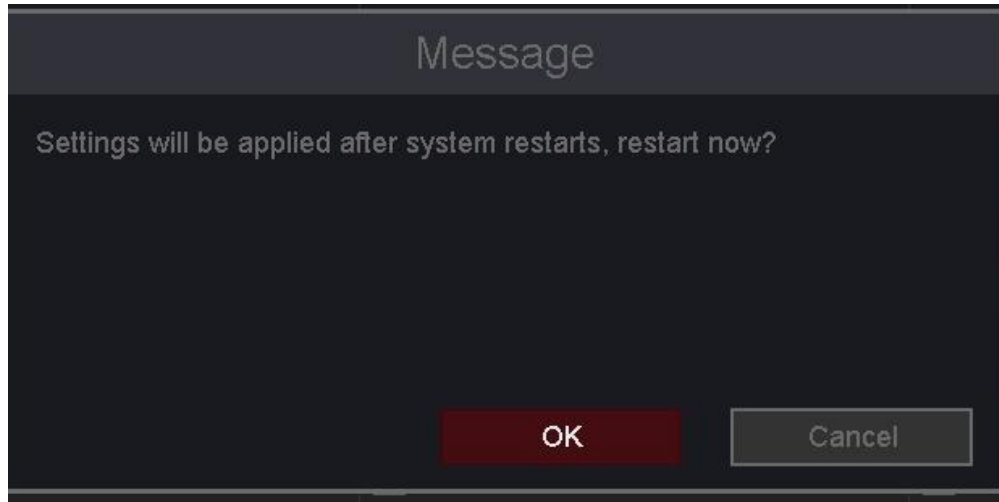

Figure 2-15 Click OK

4. Go to **Main Menu > IP Channel > Channel Set**.
5. Click **Search**. The online cameras within the same network segment will be detected and displayed in the camera list.

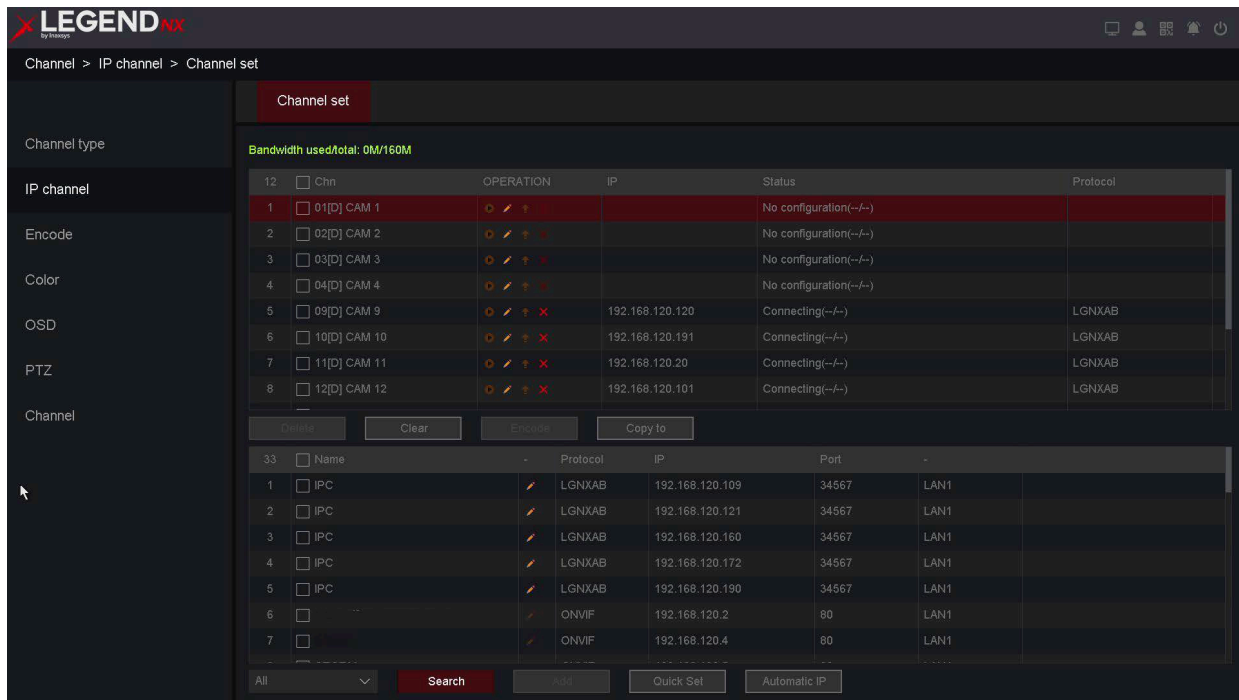

Figure 2-16 Search IP Cameras

6. Check the camera status:
 - “Connected” indicates a successful connection;
 - “Connecting” indicates the device is in the process of connecting;
 - “Identifying error” indicates an incorrect password.

Any status other than “Connected” indicates that the connection information should be checked and corrected to ensure proper camera connectivity.

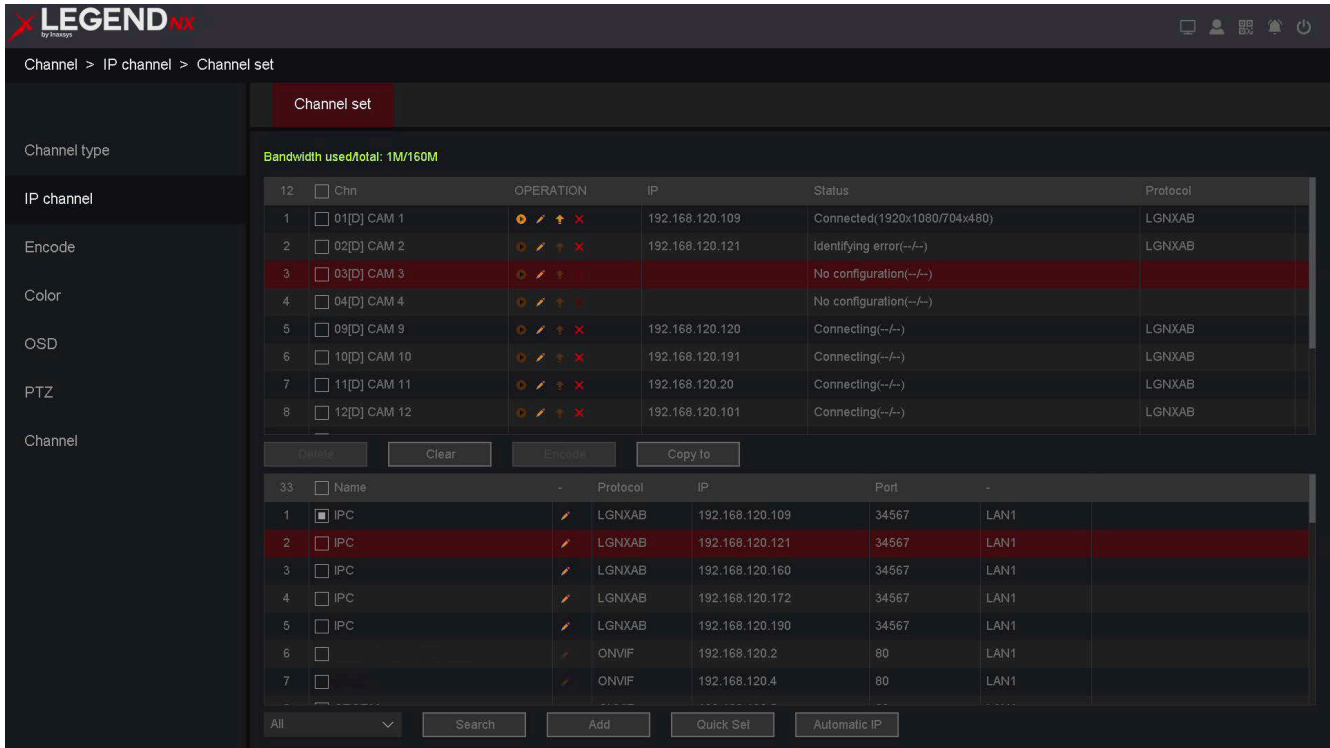





Figure 2-17 Check the status of the camera

Note

- If the camera does not display in the selected position after double-clicking, try deleting the connection by clicking the red “X”, then double-click the IP address again to add it.
- Icon descriptions:

			
View live video from the camera	Edit basic camera parameters	Upgrade the camera	Delete the IP camera

Option 2:

Steps:

1. In the **Channel Set** interface, click the edit icon  to open the **Edit IP Camera (Custom)** interface.
2. If the password is incorrect, enter the correct username and password. If the status remains “Connecting,” modify the port or protocol settings.

Figure 2-18 Edit IP Camera (Custom) interface

2.5 Editing the Connected IP Cameras and Configuration

Custom Protocols

After adding IP cameras, their basic information will be displayed on the page. You can configure the basic settings of the IP cameras.

Steps:

1. Click the edit icon to modify parameters. You can edit the IP address, username, password, port, and other settings.

Figure 2-19 Edit the parameters

2. Click the **Protocol** drop-down list to select from three protocols: **LGNXAB**, **ONVIF**, and **RTSP**. LGNXAB is a private protocol, while ONVIF and RTSP are commonly supported by third-party cameras.
3. Click **OK**.

3. Live View

3.1 Introduction of Live View

Live view displays real-time video from each connected camera. The UVR automatically enters Live View mode when powered on. It is also located at the top level of the menu hierarchy, so repeatedly right-clicking (depending on the current menu level) will return you to Live View mode.

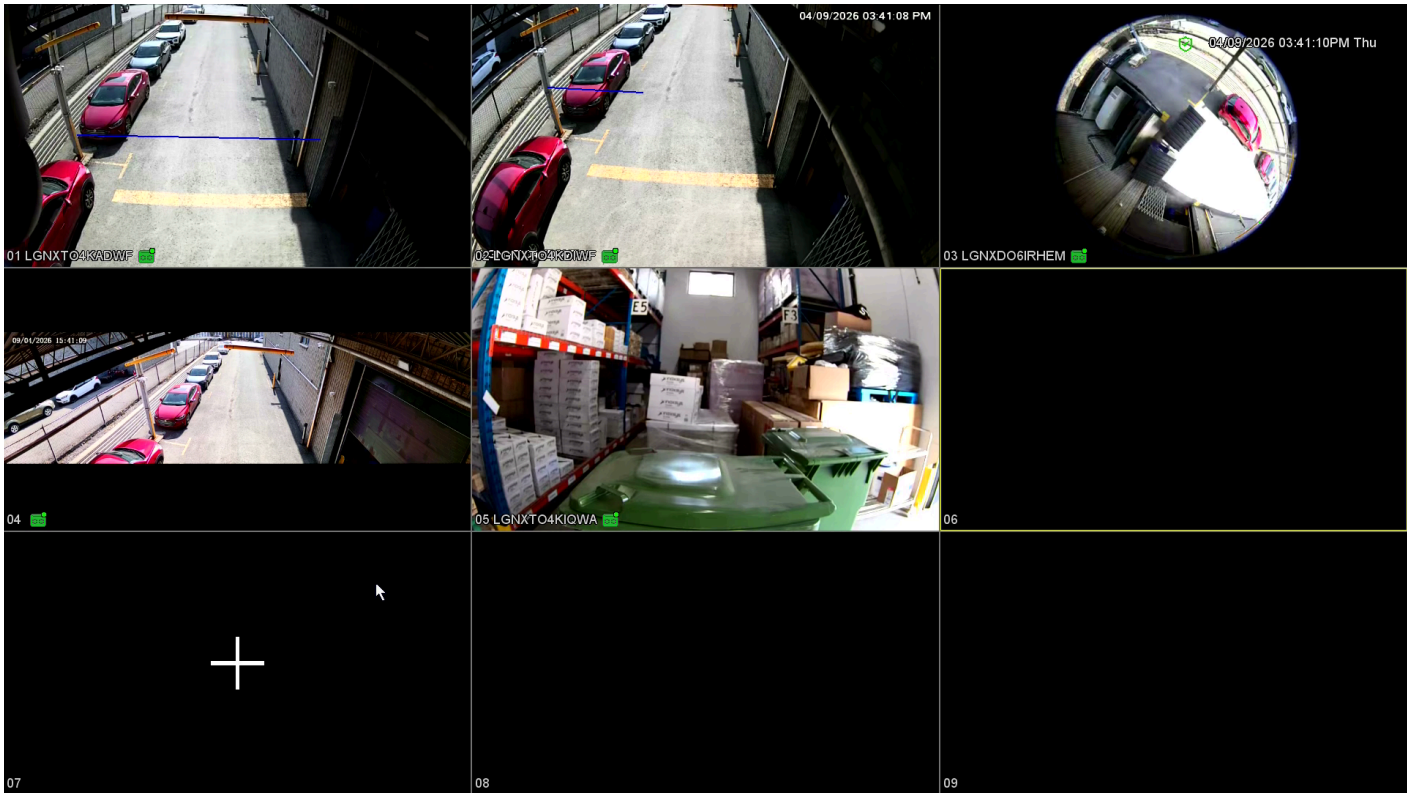



Figure 3-1 Live view

In Live View mode, status icons are displayed at the bottom-left corner of each channel window. These icons indicate recording and alarm status, allowing you to quickly determine whether a channel is recording or if an alarm has been triggered.

Table 3-1 Live View Icons

Icon	Items	Description
	Recording status	Displayed on the channel preview during recording.
	Alarm detect	Displayed on the channel preview when an alarm is triggered.
	Video loss	Displayed on the channel preview when video is lost.

	Camera lock	Indicates no preview permission.
---	-------------	----------------------------------

Note

- In Live View, go to **Main Menu > Camera > Channel > Channel Set** to access the camera interface. Click **Search** to automatically detect IP cameras on the same network segment, then select the desired camera and click **Add**. Refer to **2.4 Adding Online IP Cameras**.
- The number of supported IP camera channels may vary depending on the model.

3.2 Operations in Live View Mode

In Live View mode, the following functions are available:

- **Single Screen:** Displays one channel in full screen.
- **Multi-screen:** Displays multiple channels simultaneously.
- **Tour:** Automatically switches between channels. The dwell time for each channel must be configured in the settings menu before enabling this function.







3.3 Quick Setting Toolbar in Live View Mode



Each channel window includes a quick setting toolbar that appears when you move the cursor to the top of the image.



Figure 3-2 Quick Setting Toolbar in channel image















Table 3-2 Quick Setting Toolbar





Button	Items	Description
	Instant Replay	Replay recent video (within the last 1–30 minutes) in the preview window.
	Zoom	Display the selected channel in full screen. Use the mouse wheel to zoom into the selected area.
	Manual Record	Manually start or stop recording.
	Manual Snapshot	Capture a snapshot at the current display resolution in real time.
	Audio Preview	Enable or disable audio for the selected channel.
	Voice Intercom	Enable two-way audio communication.

	Channel Set	Quickly access the channel management interface.
	Bitrate	Display the current bitrate when the cursor hovers over the channel.
	PTZ	Quickly access the PTZ control interface.

In preview mode, right-click to open the shortcut menu, as shown below.

Table 3-3 Right-Click Menu

Icon	Items	Description
	Main Menu	Access playback, settings, maintenance, backup, and shutdown options.
	Startup Wizard	Refer to section 2.2 for more information about the Startup Wizard.
	Auto Channel Config	Automatically adds IP cameras on the same LAN.
	IP Channel	Shortcut to the IP channel interface.
	Channel	Shortcut to the channel status interface.
	Playback	Shortcut to the playback interface.
	Quick Record	Indicates current channel selection status (“o” not selected, “●” selected).
	PTZ Control	Includes PTZ direction, speed, zoom, focus, iris, presets, patrol, and tour functions.
	Coaxial Control	Adjust the HD analog camera video output signal. Refer to section 3.3.1 for details.
	Color Setting	Shortcut to Settings > Channel Management > Image Color Settings.
	Output Adjust	Shortcut to System > Display > Output Settings.
	Mute	Toggle speaker audio on  or off  .
	Guard/Disarm	Quickly enable or disable all alarm and event triggers.

	Shutdown	Access shutdown, restart, logout, and user switching options.
	View 1	Display a single-channel view.
	Multiple Views	Display 4/6/8/9/16 split-screen views.
	Corridor Mode	Display 3/4/5/7/9/10/12/16 split-screen layouts based on selection.

3.3.1 Coaxial Control from UVR

Steps:

1. Select the HD analog camera for which you want to modify the video output settings in the preview interface.
2. Right-click and select **OSD Coaxial Control**.

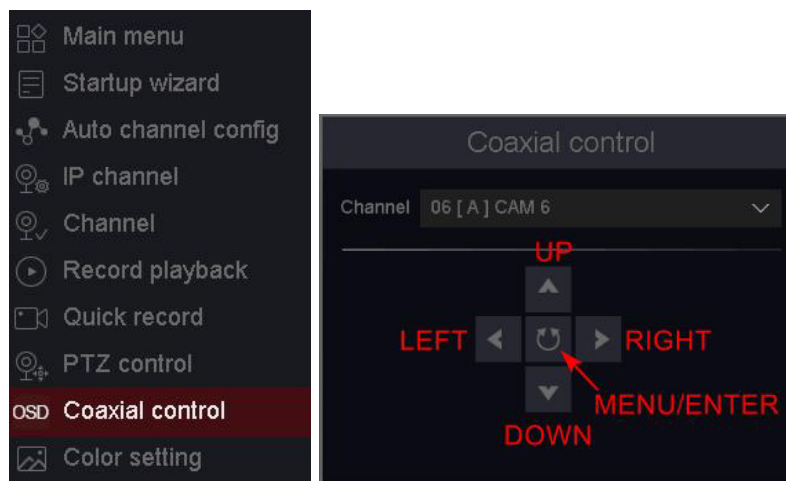

Figure 3-3 OSD Coaxial Control

3. UTC Control from UVR (U Series Varifocal & Fixed Lens Cameras)

- (1) Click the central **MENU** button in the UI or press the joystick.
- (2) Move the cursor to **VIDEO SETTING** and press the central **MENU** button.
- (3) Under **HD**, use the left and right controls to select the video output format: TVI, CVI, CVBS, or AHD.
- (4) Under **Video Standard**, use the left and right controls to select 4MP or 5MP resolution (for Q-C series, select 25 fps or 30 fps frame rate).
- (5) Go to **Reboot & Apply** to apply the changes and restart the camera.

4. UTC Control from UVR (Q Series Varifocal & Fixed Lens Cameras)

- (1) Click the central **MENU** button in the UI or press the joystick.
- (2) Move the cursor to **FORMAT**, then use the left and right controls to select 25 fps or 30 fps frame rate.
- (3) Move the cursor to **VIDEO MODE**, then use the left and right controls to select TVI, CVI, CVBS, or AHD

video output.

(4) Click the central **MENU** button in the UTC interface to confirm. The camera will restart automatically.

4. Playback

4.1 GUI Introduction

Go to **Playback**.



Figure 4-1 Playback

- The functions of each area in the figure above are described as follows:

Table 4-1 Area Functions Introduction of Playback

No.	Items	Description
1	Playback Type	The UVR supports six playback modes: Normal Play, Event Play, Label Play, Smart Play, Time Division Play, and Picture Playback.
2	Display	Displays video playback.
3	Camera List	Allows you to select channels for playback.

4	Date	Displays dates with available recordings (highlighted in blue).
5	Time of File	Displays the start and end times of recorded files on the HDD.
6	Timeline	Displays the playback progress and recorded segments.

- The video playback timeline is shown below.



Figure 4-2 Timeline

1. Position the cursor on the timeline and drag it to a specific time.
2. Periods marked in blue indicate recorded video. Red bars indicate event recordings.
3. Click **Timeline Zoom In/Out** at the bottom-right of the timeline to adjust the time scale.

Note

The second row displays all files for the selected channels. The first row shows files for the channel selected in the display area. Event files are marked in red, normal files in blue, and smart files in green.

• **Tool Menu Description in the Playback Interface**

Table 4-2 Tool Menu Description

Button	Items	Description
	Mute	Toggle audio playback for the selected channel.
	Cut	Clip a segment from the current playback video.
	Snapshot	Capture an image from the current playback.
	Lock Record	Lock the file to prevent it from being overwritten.
	Default Label	Apply a default label to the file.
	File Management	Manage clipped, locked, and labeled files.
	Zoom	Zoom in on the playback video.

4.2 Normal Playback

Play back recorded video.

Steps:

1. Go to **Playback**.
2. Select a camera from the camera list.
3. Select a date from the calendar.

Note

- Dates highlighted in blue indicate that recordings are available. For example, a highlighted date (e.g., 9) indicates available video, while a non-highlighted date (e.g., 10) indicates no recordings.

- If no recording files are found, verify that a recording schedule has been configured. Refer to **6.4.2 Configure Recording Schedule** for details.

4. Click the timeline to start playback.

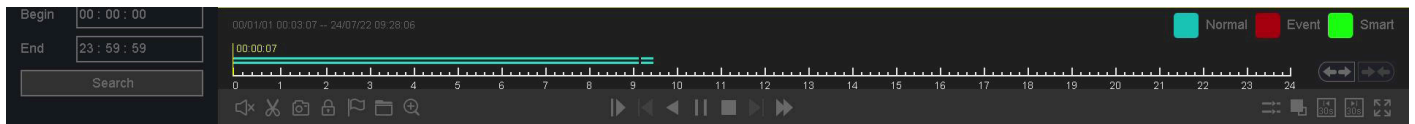















Figure 4-3 Timeline

5. Video playback can be controlled using the following buttons:

Table 4-3 Playback Interface Description

Button	Description	Button	Description
	Slow down		Previous frame
	Backward playback		Start playback
	Pause		Stop playback
	Next frame		Speed up
	Synchronous/asynchronous playback switching		Main/sub stream switching
	Backward 30 seconds		Forward 30 seconds
	Full screen		Multi-speed playback

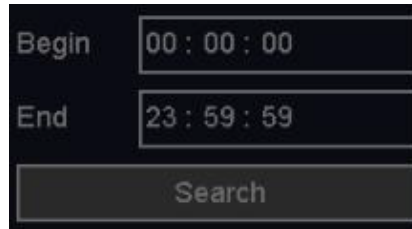

6. To play back a specific time period, set the recording start time and end time under the calendar.



The image shows a dark-themed interface for selecting a time range. It features two input fields: 'Begin' with the value '00 : 00 : 00' and 'End' with the value '23 : 59 : 59'. Below these fields is a 'Search' button.

Figure 4-4 Select time

7. Refer to the table above for the functions of each playback control button.

- Clicking the cut icon  will clip the current playback files of the selected channels. You can view the clipped files in the **File Management**  interface.

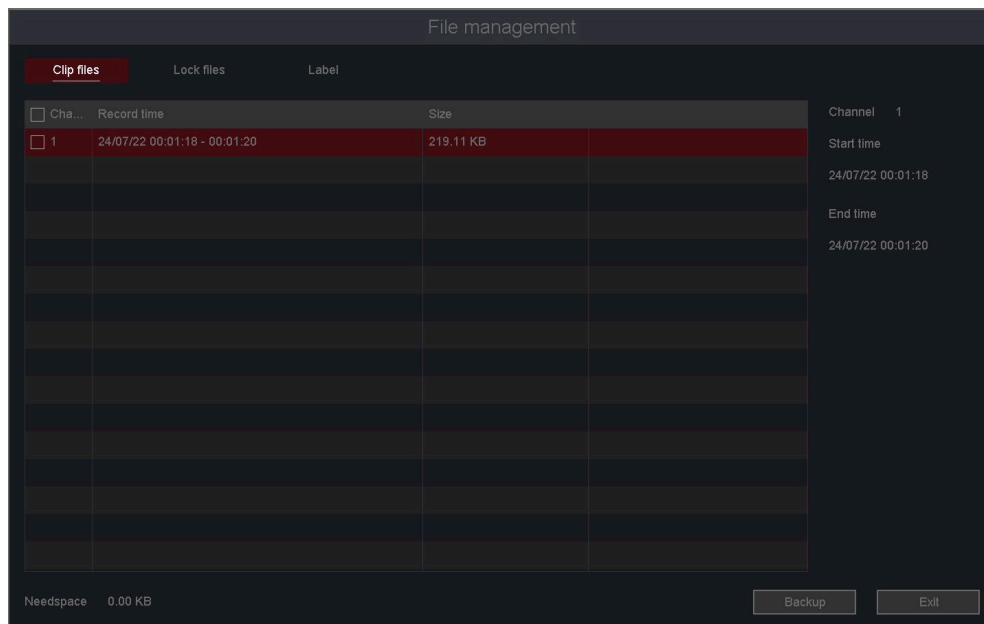



Figure 4-5 File Management

- Click the **Lock** icon  to lock the file and prevent it from being overwritten by new recordings. You can view and back up locked files in the **File Management**  interface. Locked files can be unlocked in the **Lock Files** section.

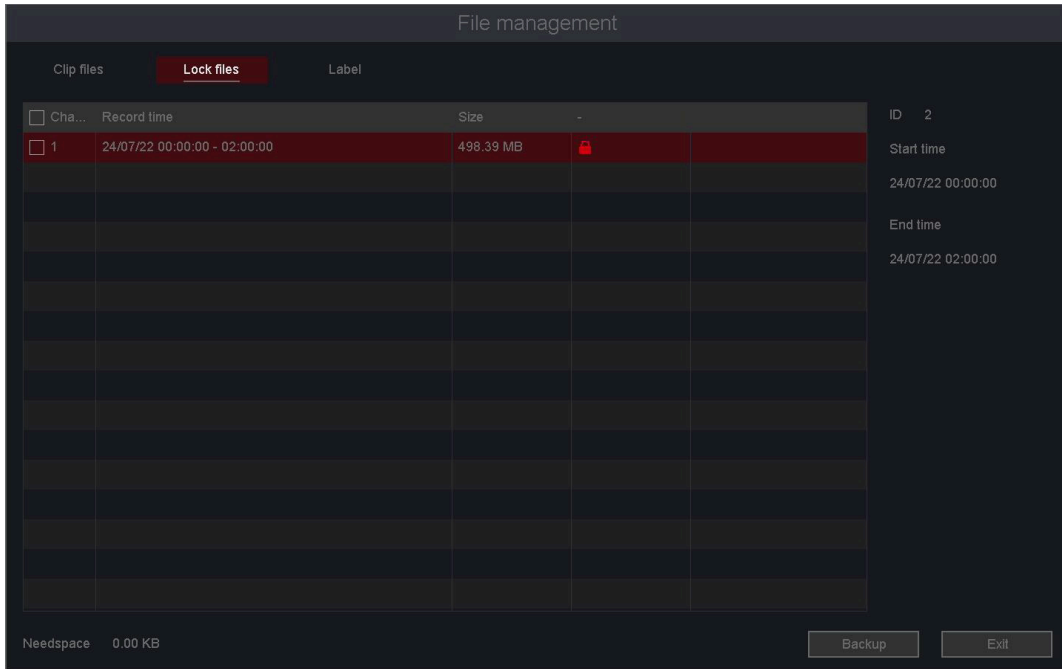



Figure 4-6 Lock files

- Click the **Label** icon  to assign a default label to the video. You can edit and review labels in the **Label** section.

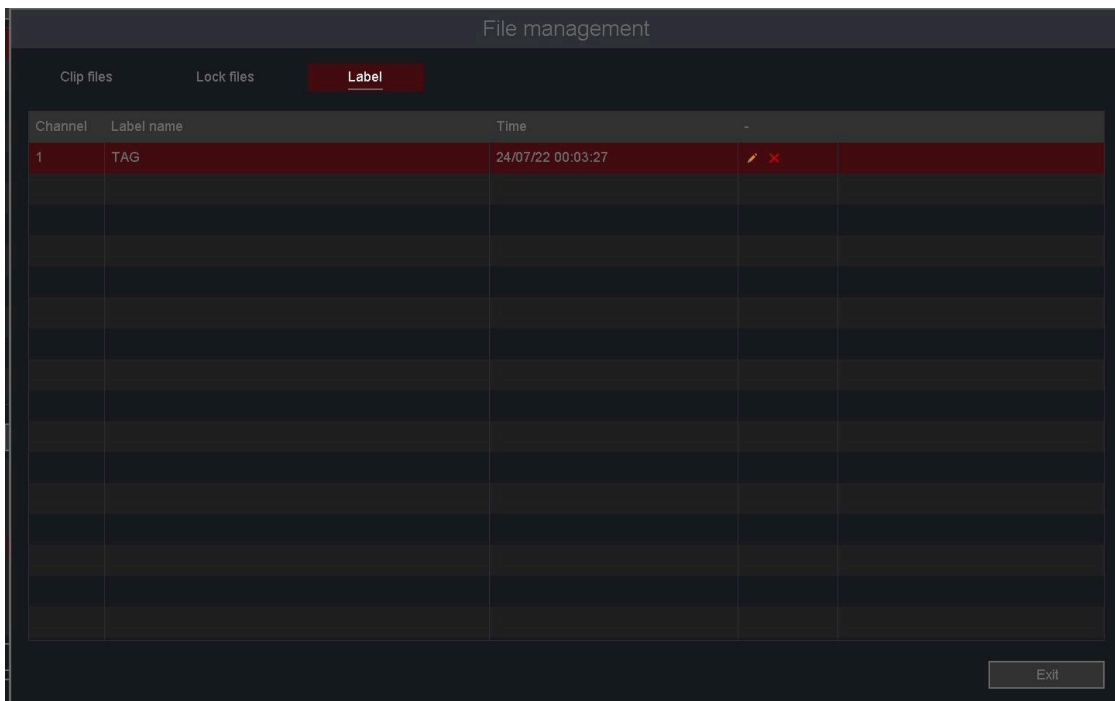

Figure 4-7 Label

4.3 Event Playback

In Event Playback mode, the system analyzes and marks video segments containing events such as motion detection, line crossing detection, or intrusion detection.

Before you start

- Ensure that the camera has enabled **Motion Detection**, **Perimeter Protection**, or **Diagnosis**. You can enable these via **Main Menu > Normal Event** or **Smart Event > Motion Detection, Perimeter Protection**, or other related options.
- Ensure that the video recorder has enabled **Record Channel** in the **Trigger Process** settings. You can configure this via **Main Menu > Normal Event** or **Smart Event > Motion Detection, Perimeter Protection**, or other options > **Trigger Process**.

Steps:

1. Go to **Playback**.
2. Click **Event Play**.
3. Select a camera.
4. Set the time period, then click **Search**.
5. The search results are shown as in Figure 4-8. “Source” indicates the alarm channel, “Channel” indicates the recording channel for linked actions, and “Time” indicates when the event occurred.

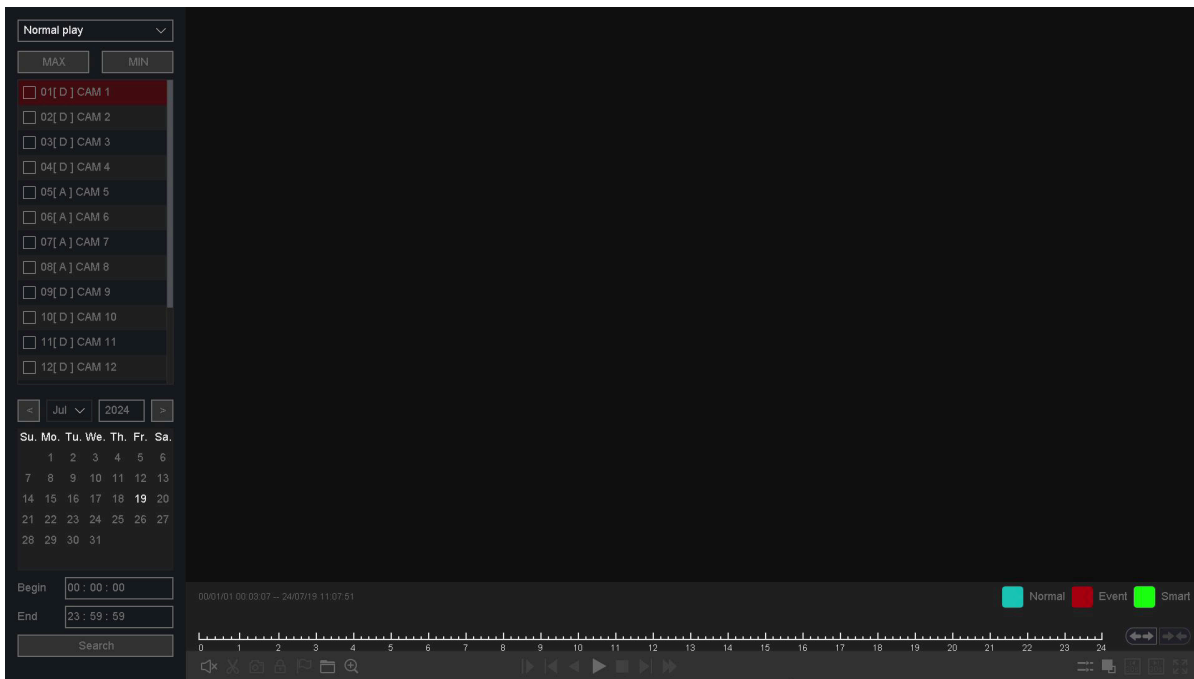







Figure 4-8 Event Playback

6. Click **Next** to display all alarm events. You can switch pages to locate the desired event and set the playback time before or after the event.
7. Click **Return** to go back to the previous interface and modify the alarm type or channel. Refer to the table below for button operations. Note that **Sync/Async** and **Main/Sub Stream** options are not available in Event Playback mode.

Table 4-4 Button Description of Event Search Results

Button	Description	Button	Description
--------	-------------	--------	-------------

	Go to the first page of event search results		Go to the last page of event search results
	Go to the previous page of event search results		Go to the last page of event search results
	Go to the next page of event search results		

4.4 Backup Clip

You can clip video segments during playback. These clips can be exported to a backup device (such as a USB flash drive).

Before you start

Connect a backup device to the video recorder.

Steps:

1. Start playback. Refer to **Chapter 4 Playback** for details.
2. Click the cut icon at the desired start time.
3. Click **Stop Cutting** at the desired end time.
4. View the clipped files in the **File Management** interface.
5. Select the video files to back up.
6. Click **Backup** to open the recording backup interface.
7. Select the backup device and destination folder.
8. Click **Start** to export the selected clips to the backup device.

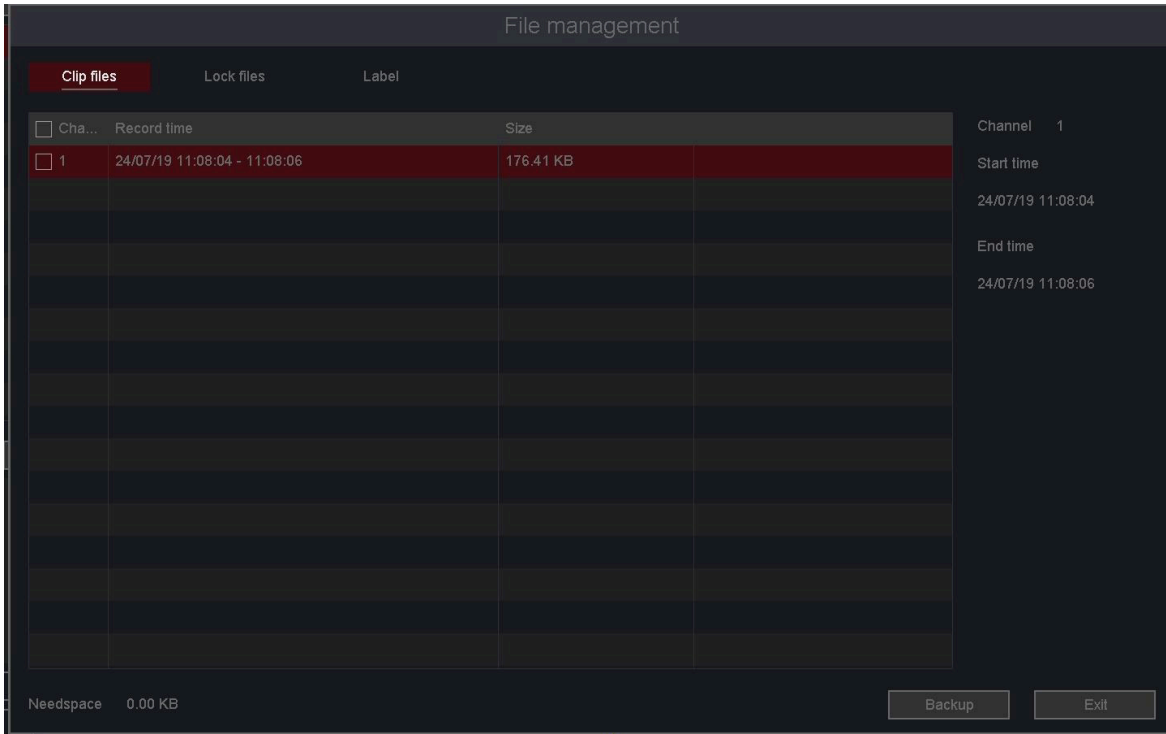

Figure 4-9 Record Backup

5.Backup

You can back up video recordings by exporting them to backup devices (such as a USB flash drive).

Before You Start

Connect a backup device to your video recorder.

Steps:

1. Go to **Backup** → **General**.

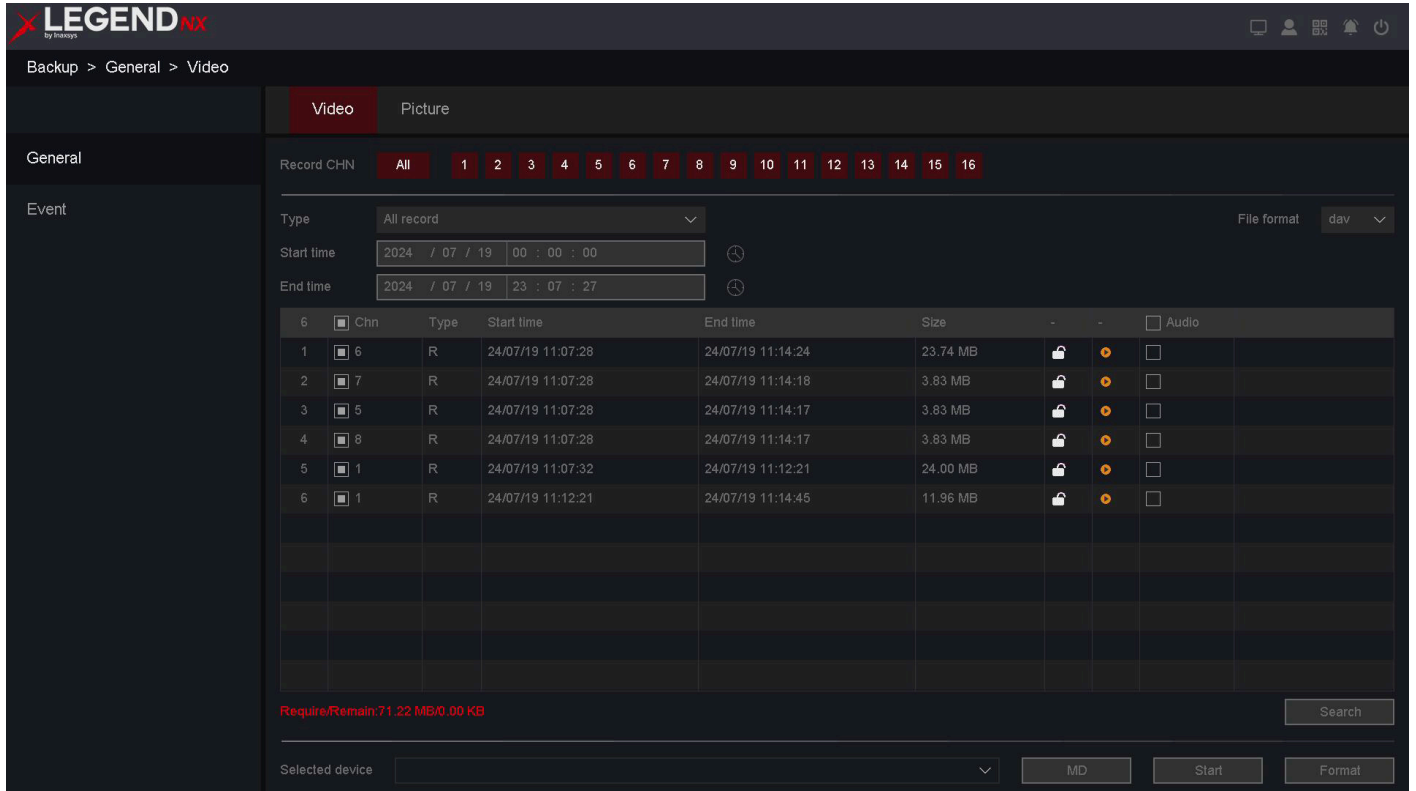



Figure 5-1 Search

2. Select a search type.
3. Set the search conditions.
4. Click **Search**.
5. Click the play icon  to play the video.
6. Click the lock icon  to lock the file. Locked files will not be overwritten.
7. Select the file(s).
8. Select the backup device and destination folder.
9. Click **Start** to export the selected file(s) to the backup device.

Note

If the backup device is not detected, unplug and reconnect it. If the backup fails, click the **Format** button to format the device first.

6. Configuration (Common Mode)

Easy mode provides basic configuration options.

6.1 System Settings

6.1.1 General Configuration

You can configure the language, time zone, system time, Startup Wizard, device number, host name, and other basic settings.

Steps:

1. Go to **Main Menu** → **System** → **Basic**.

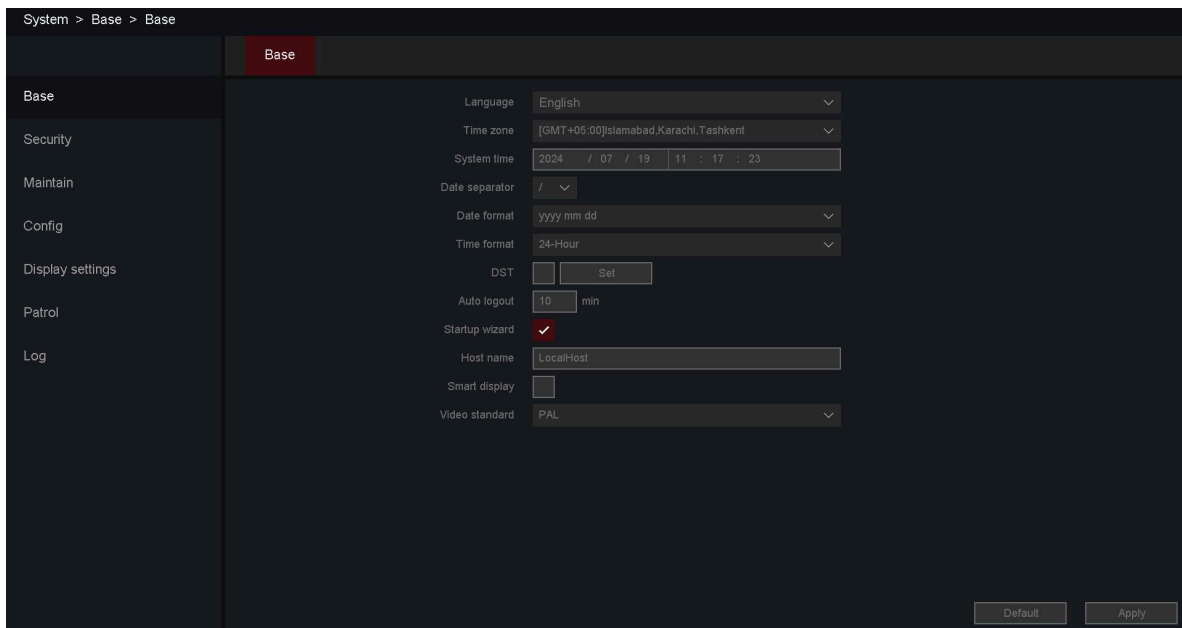

Figure 6-1 Basic Setting

2. Configure the parameters as needed.

Time Format

Defines how the time is displayed.

Auto Logout

Sets the automatic logout duration. If set to **0 minutes**, the device will not log out automatically. The maximum setting is **60 minutes**.

Startup Wizard

Determines whether the wizard appears automatically when the device starts.

Device No.

Required when connecting with a remote control. This is the device ID of the video recorder. The valid range is **1 to 998**.

Host Name

The name assigned to the UVR device.

Video Standard

Set the video standard to **NTSC** or **PAL**.

3. Click **Apply**.

6.1.2 Account

Add User

There is a default account: **Admin**. The default administrator username is **admin**. The administrator has permission to add, delete, and modify users.

Steps:

1. Go to **Main Menu** → **System** → **Security** → **Account**.
2. Click **Add User** and confirm the administrator password.

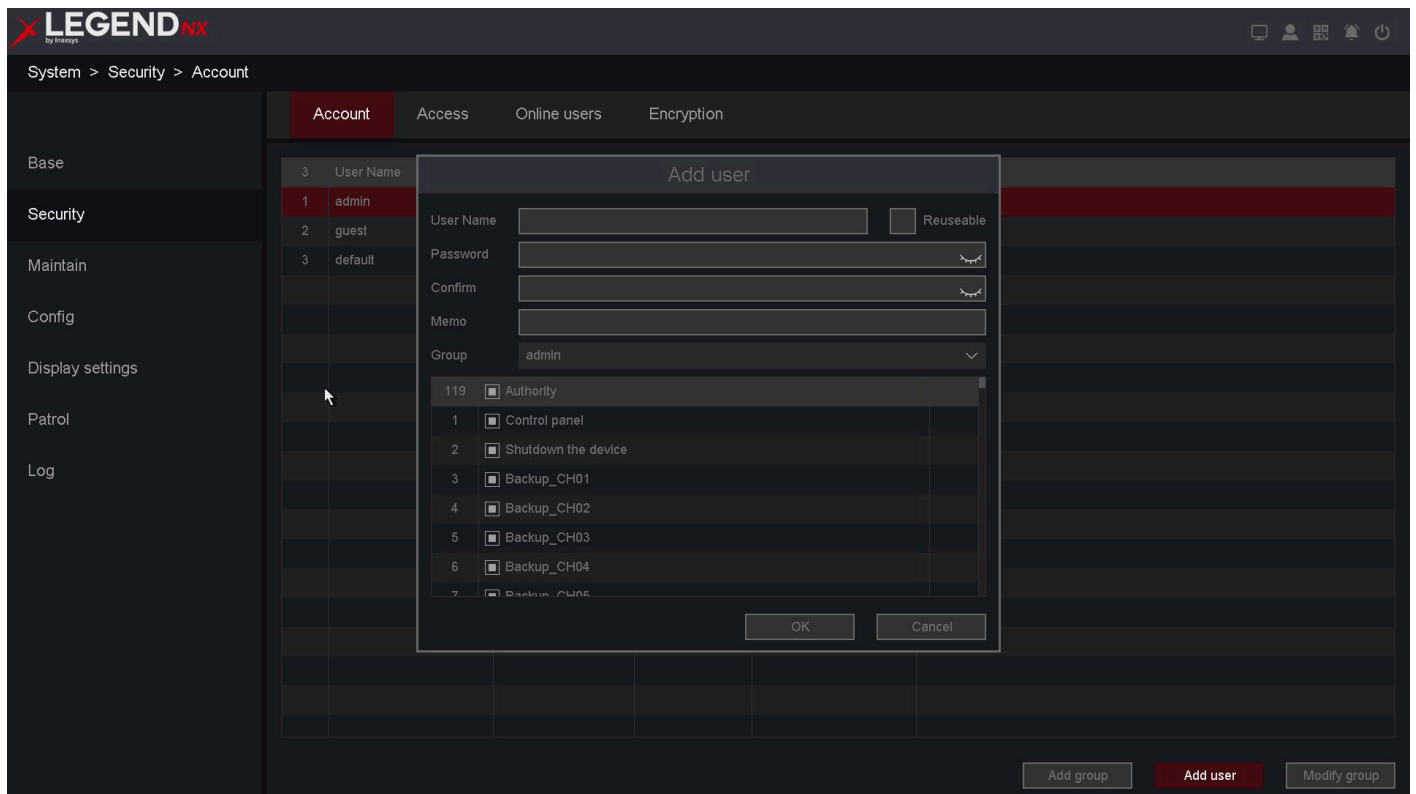

Figure 6-2 Add User

3. Enter the **User Name**.
4. Enter the same password in **Password** and **Confirm**.

Note

It is strongly recommended to create a secure password (8–16 characters) that includes at least two of the following: uppercase letters, lowercase letters, numbers, and special characters. To enhance system security, change your password regularly. In high-security environments, it is recommended to update the password weekly or monthly.

5. Click **OK**.

Click the edit  or  icons to modify or remove a user.

Modify Password

You can change your password if it has been compromised.

Steps:

1. Click the edit icon  in the **Account** interface.

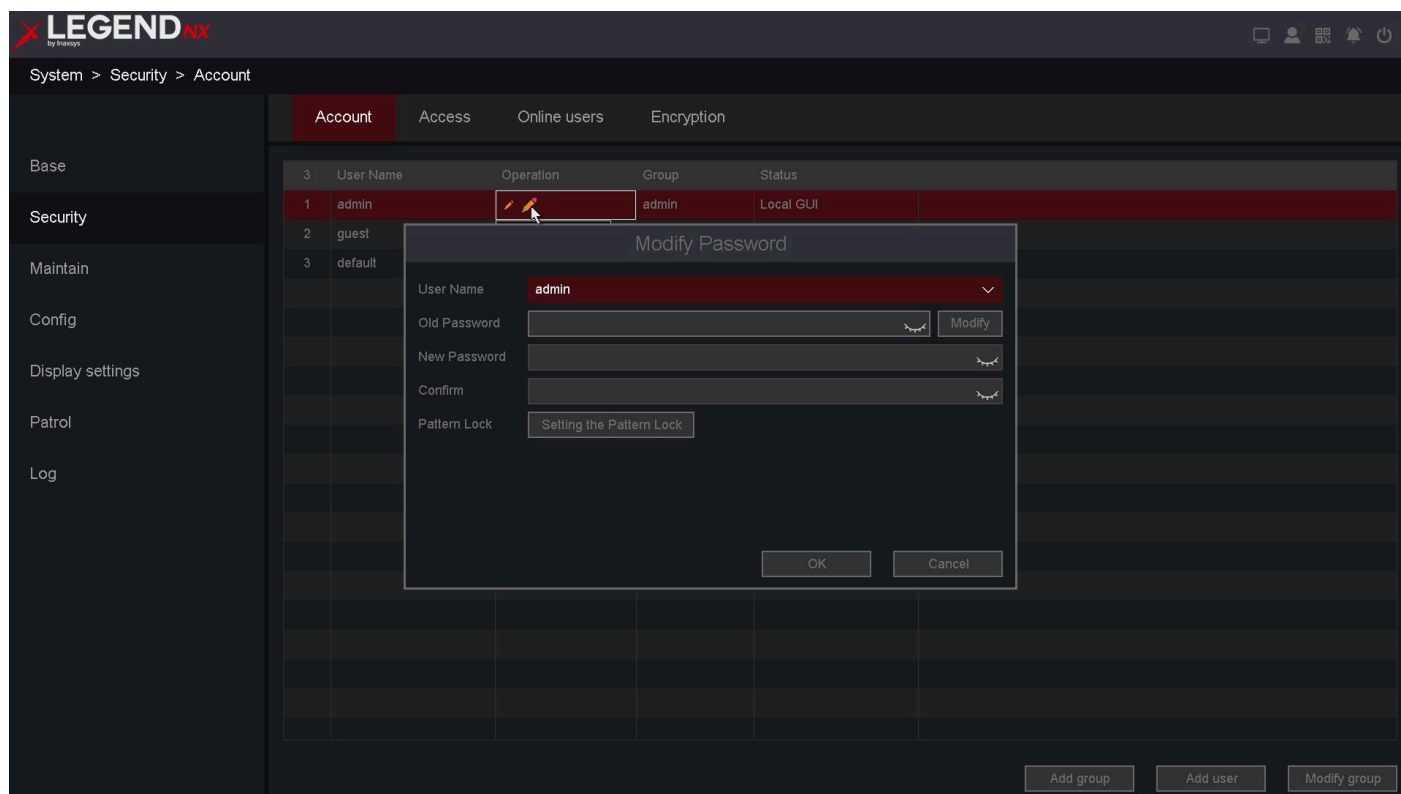

Figure 6-3 Modify Password

2. Enter the **Old Password**.
3. Enter the same new password in **New Password** and **Confirm**.
4. Click **OK**.
5. Optional: The administrator can also set a pattern lock by clicking **Set the Unlock Pattern**.

6.2 Network Configuration

6.2.1 General - TCP/IP

You must configure the network settings correctly before using the device over a network.

Steps:

1. Go to **Main Menu** → **Network** → **Base** → **IP Setup**.

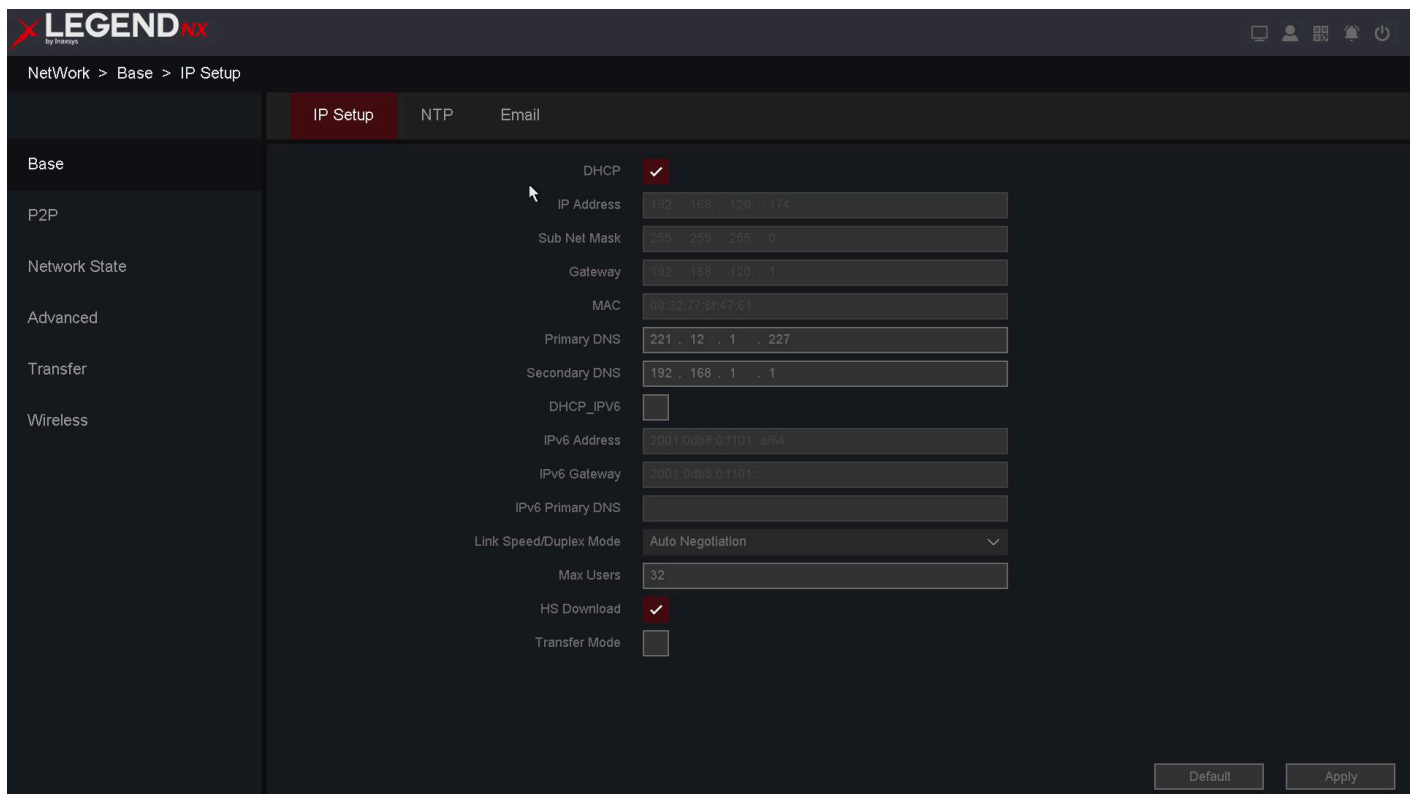

Figure 6-4 Network

2. Set the network parameters.

DHCP

If a DHCP server is available, enable **DHCP** to automatically obtain an IP address and other network settings from the server.

Auto DNS

If **DHCP** is enabled, you can enable **Auto DNS** to automatically obtain the **Primary DNS** and **Secondary DNS**.

Note

The availability of automatic DNS options may vary depending on the model.

Manual IP

Manually configure the IP address, for example:

IP Address: 192.168.1.100

Subnet Mask: 255.255.255.0

Gateway: 192.168.1.1

Ensure that the IP address of the device and the camera are in the same LAN.

3. Click **Apply**.

6.2.2 P2P

We provide mobile apps and cloud services to access and manage your connected devices, allowing you to remotely monitor your surveillance system.

Steps:

1. Go to **Main Menu** → **Network** → **P2P**.
2. Enable **P2P**. The device will automatically initiate the P2P cloud registration.

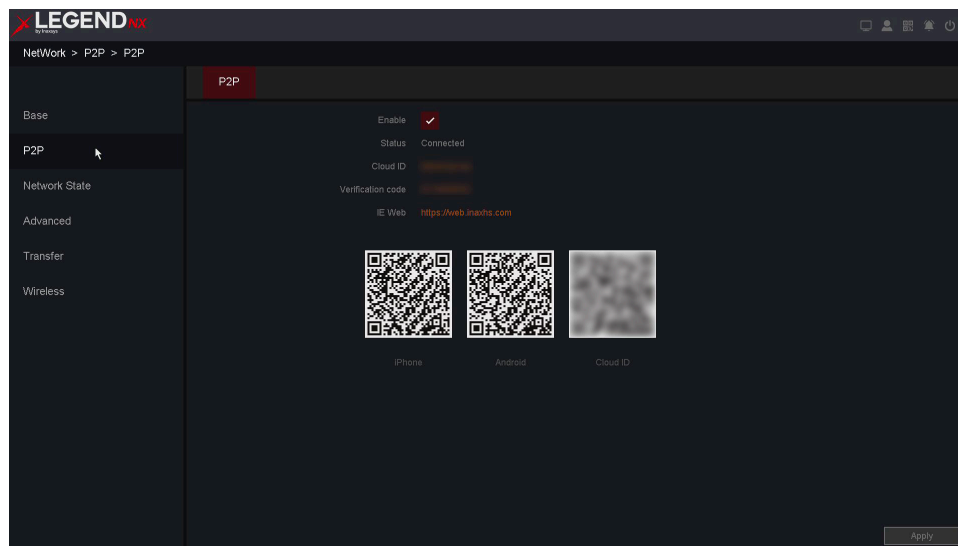

Figure 6-5 P2P Interface

3. The status will change from *Connecting* to *Connected*, indicating that the device has been successfully registered with the P2P cloud.
4. Bind the device to your cloud account.
 1. Scan the QR code using your smartphone to download the **APP**. You can also download it using the QR code below.



Figure 6-6 Download

2. Use the **LEGEND NX APP** to scan the device QR code and bind the device.

Steps:

1. Open the **APP** on your smartphone.
2. Tap **Register** in the lower-left corner of the login screen, create your account, and then log in. Creating an account allows you to manage multiple devices.
3. Open the **Menu** by tapping the icon in the top-left corner.
4. Tap **Devices**, then tap the **+** icon in the top-right corner to add a device.
5. Allow the app to access your phone's camera, then scan the device QR code (from the Startup Wizard or the device label). 'Cloud ID'. This will send the device connection information to the app.
6. Set a name for the device so it can be easily identified in the list. Using the installation location is recommended.
7. Tap **Save**, then you can start **Live View**.
8. Locate the device you added in the device list, tap the play button, and the system will open the real-time preview (sub-stream by default). Using the sub-stream can improve streaming performance and reduce mobile data usage.

Note

- You can also download the app directly from your phone's app store.
- If the device is already bound to an account, click **Unbind** to remove it from the current account.
- If manual unbinding is not supported, contact technical support.

6.2.3 Email

Configure an email account to receive event notifications.

Before You Start

- Ensure that the SMTP service is enabled for your email account.
- Configure the network settings. Refer to **6.2.1 General - TCP/IP** for details.

Steps:

1. Go to **Main Menu** → **Network** → **Base** → **Email**.

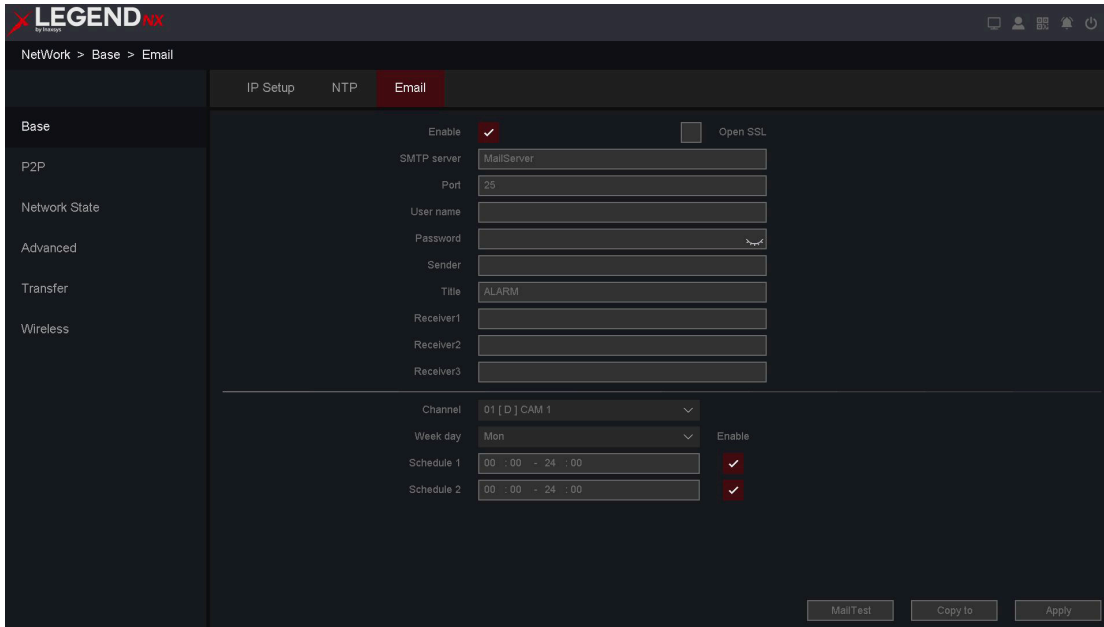

Figure 6-7 Email

2. Configure the email parameters.

Enable

Select this option to enable server authentication.

SMTP Server

Enter the address of the SMTP server, for example, *smtp.163.com*.

Port

Enter the port number used by the SMTP server. This information is provided by your email service provider.

User Name

Enter the email account used for SMTP authentication.

Password

Enter the password for the email account used for SMTP authentication.

Sender

Enter the sender name or the sender's email address.

Title

Enter the subject of the email notification.

Receiver 1–3

Enter the recipient email address(es). Up to three recipients are supported.

Channel

Select the channel for which email alarm notifications will be sent.

Week Day

Select the days on which email alarms will be sent.

Schedule

Select the time schedule for sending email notifications.

SSL

(Optional) Enable **SSL** if required by the SMTP server.

3. Click **Mail Test** to send a test email and verify that the message is successfully delivered.
4. Click **Apply**.

Note

- For network cameras, event images are sent as email attachments. Typically, one camera sends three images, depending on actual conditions.
- If email delivery fails, check whether the DNS settings are configured correctly.

6.3 Camera Management

6.3.1 Network Camera

Add Network Camera by Quick Set

Add IP cameras using the default password or cameras provided with the device package.

Before You Start

- Ensure the network camera is on the same network segment as the video recorder.
- Ensure the network connection is properly configured. Refer to **6.2.1 General - TCP/IP** for details.
- Make sure the IP camera password has not been changed manually.

Steps:

1. Go to **Main Menu** → **Camera** → **Channel** → **Channel Type**.
2. Select the IP channels, then click **Apply**.

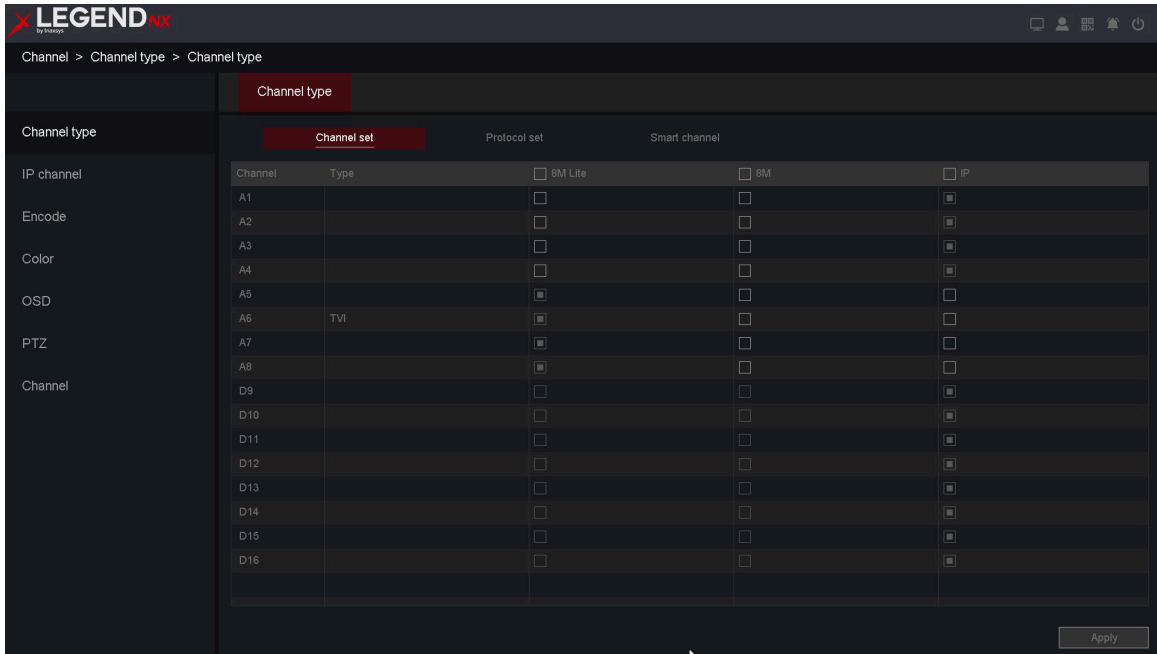

Figure 6-8 Select IP Channels

3. Click **OK** and wait for the device to restart.

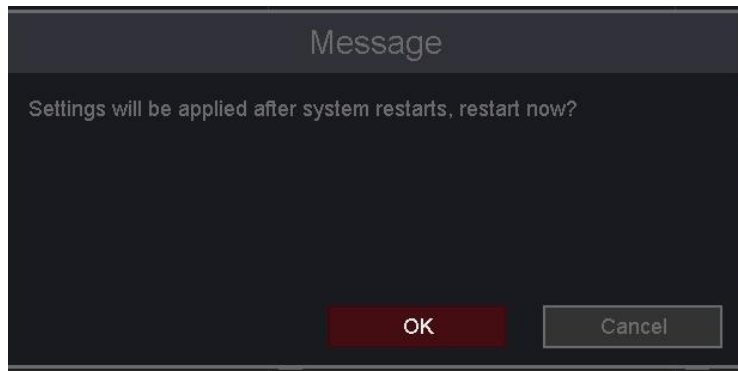

Figure 6-9 Click OK

4. Go to **Main Menu** → **Channel** → **IP Channel** → **Channel Set**.
5. Click **Search**. The system will automatically detect online cameras within the same network segment and display them in the lower section under **Online Device List**.
6. Select the cameras you want to add, or select all cameras.
7. Click **Quick Set** to add the selected cameras (using the default login password) from the list.

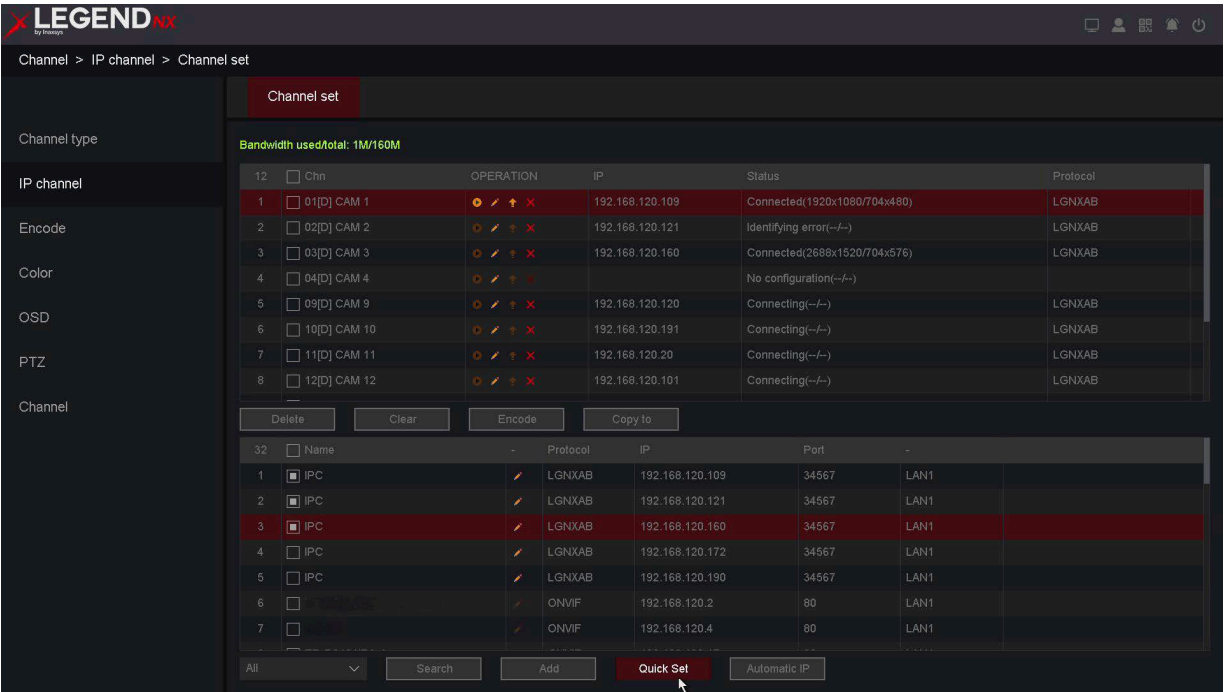

Figure 6-10 Channel Set Interface

8. The selected devices will be added automatically.

Note

If a camera cannot be added successfully, you can manually modify the user name, password, port, protocol, or other parameters.

Add Network Camera Manually

Before You Start

- Ensure the network camera is on the same network segment as the video recorder.
- Ensure the network connection is valid and properly configured.
- Ensure the network camera has been activated.

Steps:

1. Go to **Main Menu** → **Channel** → **IP Channel** → **Channel Set**.
2. Select the channel you want to add manually.
3. Click the **Edit** icon  for the selected channel.
4. Edit the IP address, user name, password, port, and other parameters as required.

Figure 6-11 Edit Parameters

5. Click the **Protocol** drop-down list to select one of the following protocols: **LGNXAB**, **ONVIF**, or **RTSP**. LGNXAB is a proprietary protocol, while ONVIF and RTSP are commonly used for third-party cameras.
6. Edit the **Channel** value. The default is 1.
7. Click **OK** to save and exit the editing interface.

Time Sync

Time synchronization. The default setting is UTC synchronization. You can also choose to disable it.

Port

Connection port for the device. The default ports are: LGNXAB: 34567, ONVIF: 80, RTSP: 554. Other ports may vary depending on the device manufacturer.

Channel

Device channel number. If the connected device supports multiple channels, enter the channel number you want to use.

Previewing Video

The camera can be previewed directly using the preview button.

Before You Start

- Ensure the network camera is on the same network segment as the video recorder.
- Ensure the network connection is valid and properly configured.
- Ensure the camera status is **Connected** and displays a resolution (for example, **(2880x1620/704x576)**) instead of **(--/--)**.

Steps:

1. Go to **Main Menu** → **Channel** → **IP Channel** → **Channel Set**.
2. Click the **Preview**  icon.

3. The preview window will appear as shown below.

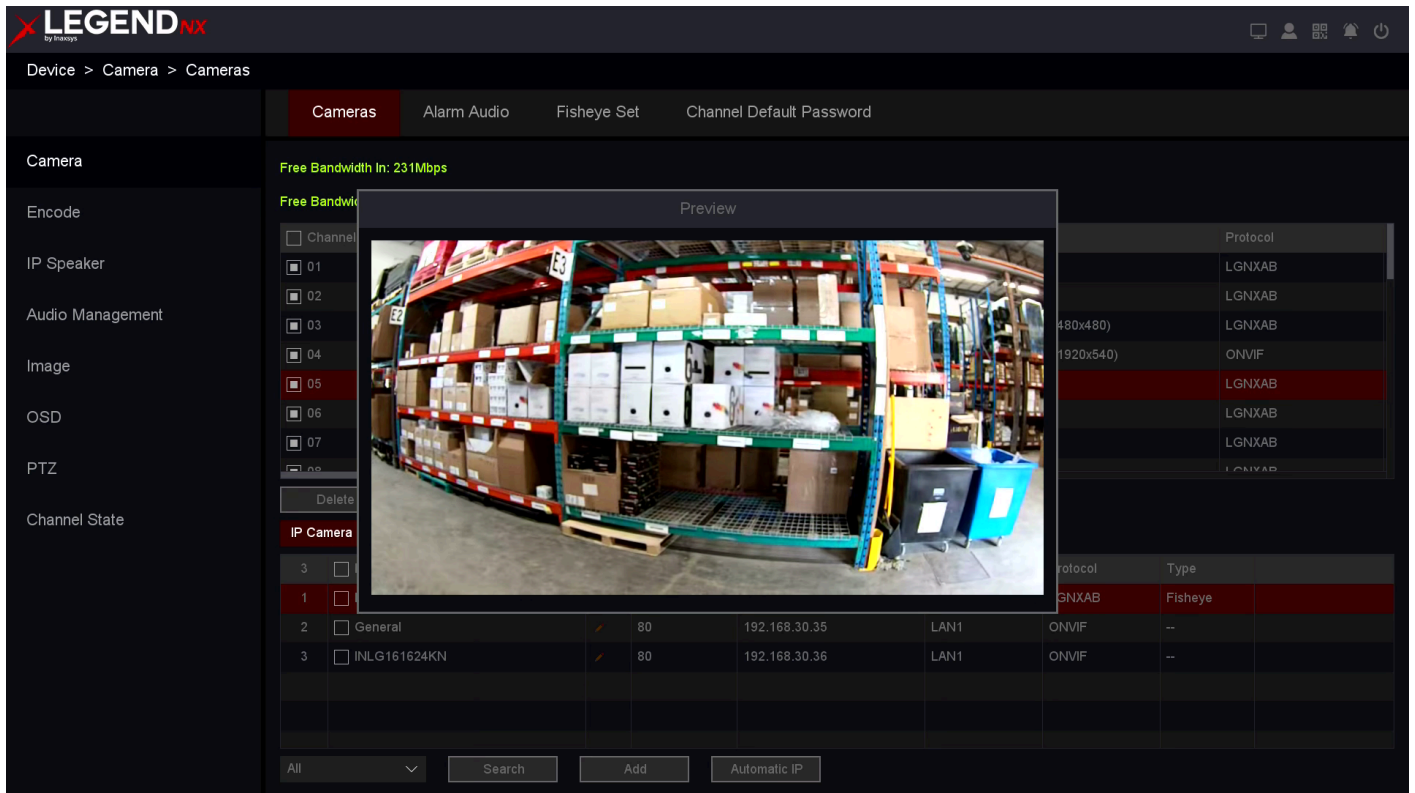

Figure 6-12 Preview

Upgrade Network Camera

The network camera can be remotely upgraded through the UVR.

Before You Start

- Ensure a USB flash drive containing the camera upgrade firmware is inserted into the device.
- Ensure the network camera is on the same network segment as the video recorder.
- Ensure the network connection is valid and properly configured.

Steps:

1. Go to **Main Menu** → **Channel** → **IP Channel** → **Channel Set**.
2. Select the camera to be upgraded.
3. Click the **Upgrade** icon.
4. Select the USB flash drive from the drop-down list.
5. Select the upgrade file and click **Upgrade**.
6. Click **OK** to start the upgrade. The camera will restart automatically after the upgrade is complete.

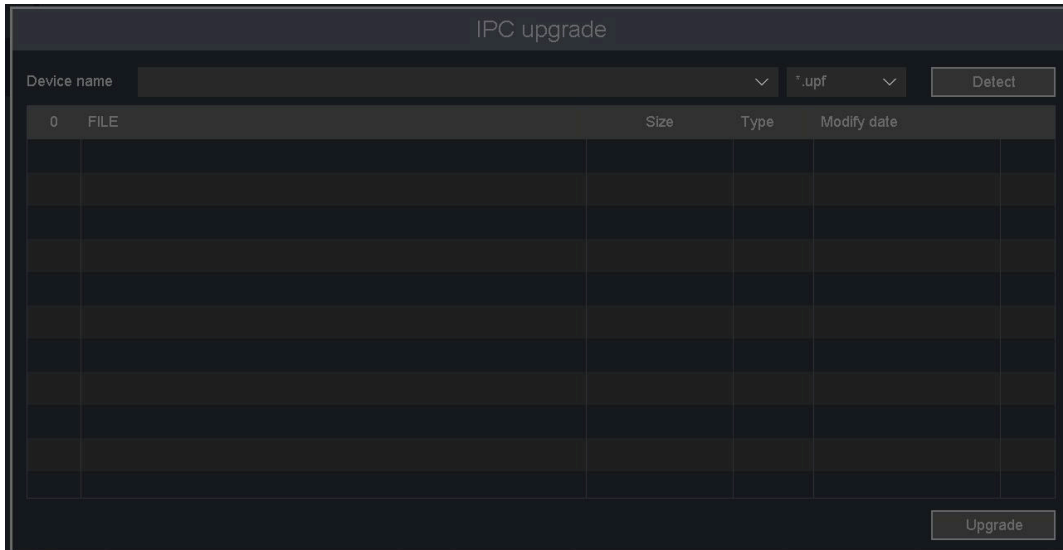

Figure 6-13 IPC Upgrade

Delete Camera

The camera can be deleted using the delete button.

Before You Start

Ensure the network camera you want to delete is selected.

Steps:

1. Go to **Main Menu** → **Channel** → **IP Channel** → **Channel Set**.
2. Click the **Delete** icon, or select the camera and click **Delete**.

OSD

Configure OSD (On-Screen Display) settings for the camera, including date format, camera name, and other information.

Steps:

1. Go to **Main Menu** → **Channel** → **OSD**.
2. Select a camera.

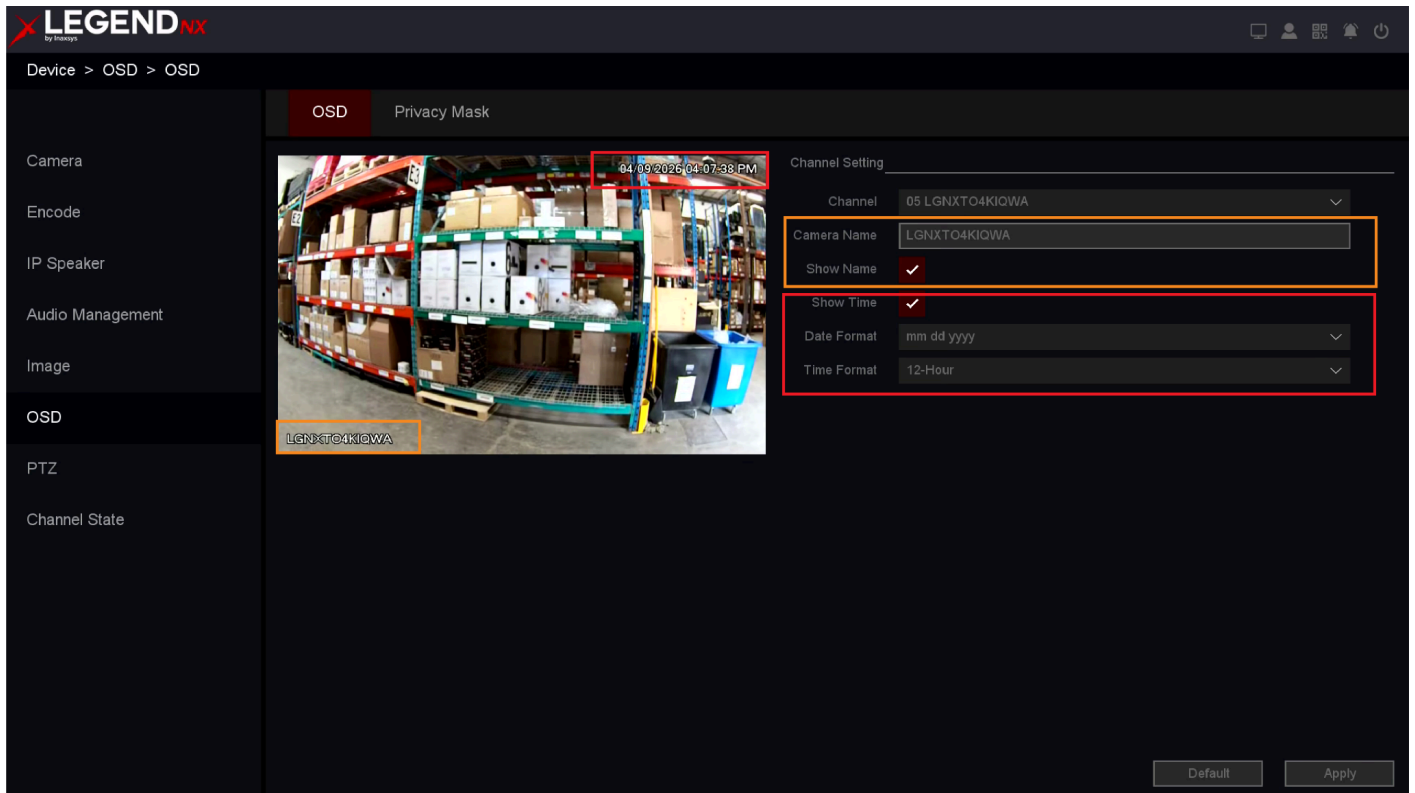

Figure 6-14 OSD

3. Configure the parameters as required.
4. You can choose whether to display the name and time, and customize them if needed.
5. Click **Apply**.

6.3.2 Event

Motion Detection

Motion detection allows the video recorder to detect moving objects within the monitored area and trigger alarms.

Steps:

1. Go to **Main Menu** → **Event** → **Detect** → **Motion**.

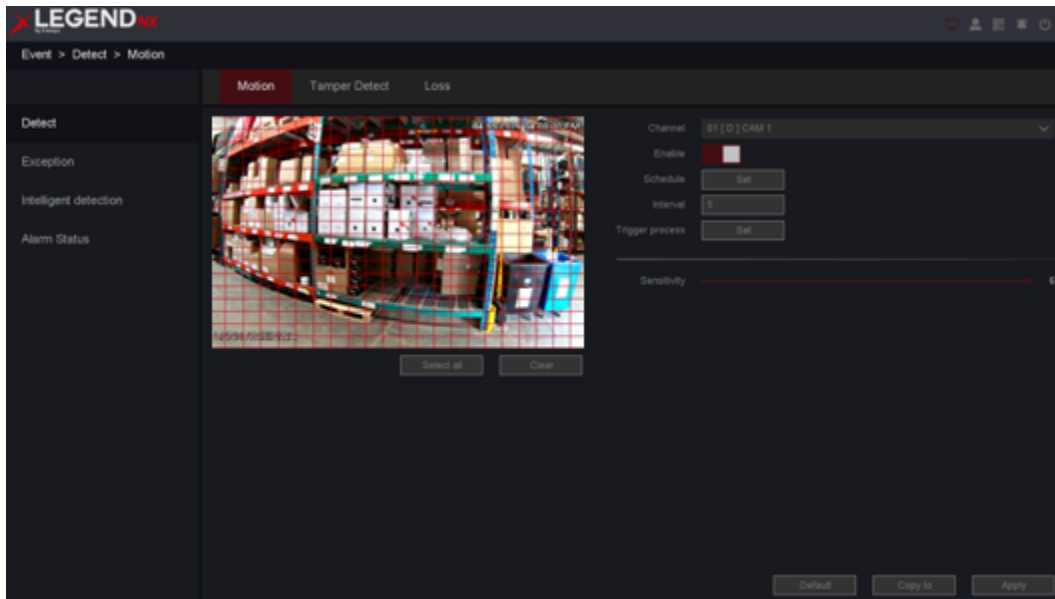

Figure 6-15 Motion Detection

2. Select a camera.
3. Enable **Enable**.
4. Configure the motion detection area.
 - Click **Clear** or press and hold the left mouse button to erase or draw detection areas. By default, the first area is set to full screen.
 - Click **Select All** to set the entire screen as the detection area. You can also drag on the preview window to define specific motion detection zones.
5. Adjust **Sensitivity**. Sensitivity determines how easily motion triggers an alarm. A higher value increases sensitivity and makes alarms more likely to be triggered.
6. Optional: Set **Target Detection** to **Human Shape Filter** or **Vehicle Shape Filter** to filter out alarms not caused by people or vehicles. This feature is only supported on certain camera models.

Note

When target detection is set to Human Shape Filter or Vehicle Shape Filter to filter out non-human or non-vehicle alarms, this function is referred to as **SMD**.

7. Configure the arming **Schedule**. Refer to **6.3.3 Configure Arming Schedule** for details.
8. Configure the **Trigger Process**. Refer to **6.3.4 Configure Alarm Trigger Process** for details.
9. Optional: You can copy the current channel settings to other channels by clicking **Copy To**.
 - When **Local** is selected, it copies the schedule, interval time, and trigger process (such as NVR buzzer, recording, etc.) to other channels.
 - When **Net** is selected, it copies the enable status, sensitivity, detection rules/areas, and advanced settings (such as camera siren or warning light) to other channels.
10. Click **Apply**.

Line Crossing

Line crossing detection identifies people, vehicles, or objects crossing a defined virtual line. The detection direction can be set to bidirectional, from A to B, or from B to A.

Steps:

1. Go to **Main Menu** → **Event** → **Intelligent Detection** → **Line Crossing**.

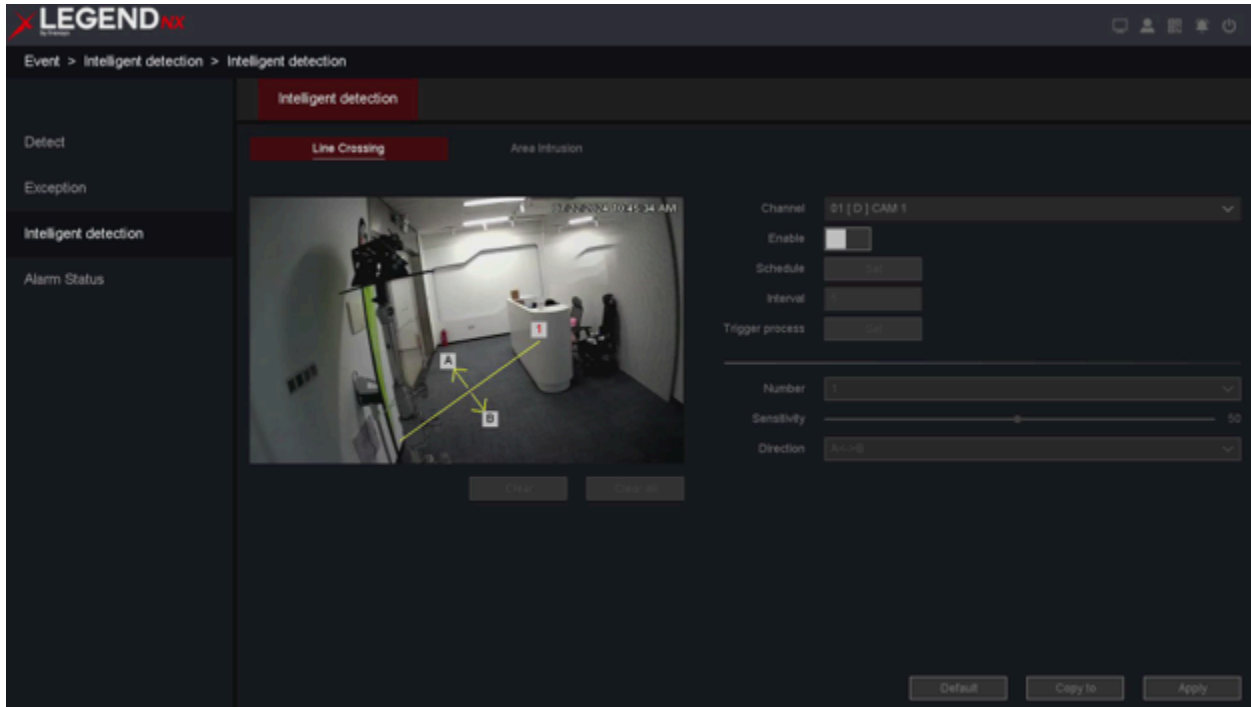

Figure 6-16 Line Crossing

2. Select a camera.
3. Enable **Enable**.
4. Configure the line crossing detection rules and draw the detection line.
 1. Select **Number** to set the arming line. Up to 4 lines can be configured. Click **Clear** or set two points in the preview window to clear or draw a line.
 2. Select the **Direction**: **A↔B**, **A→B**, or **B→A**.

A↔B

Objects crossing the configured line in either direction will be detected and trigger alarms.

A→B

Only objects crossing the line from side A to side B will be detected.

B→A

Only objects crossing the line from side B to side A will be detected.

3. Adjust **Sensitivity**. Higher values increase the likelihood of triggering detection alarms.
5. Configure the arming **Schedule**. Refer to **6.3.3 Configure Arming Schedule** for details.
6. Configure the **Trigger Process**. Refer to **6.3.4 Configure Alarm Trigger Process** for details.
7. Click **Apply**.

Area Intrusion

Area intrusion detection identifies people, vehicles, or objects entering and remaining within a predefined virtual area.

Steps:

1. Go to **Main Menu** → **Event** → **Intelligent Detection** → **Area Intrusion**.

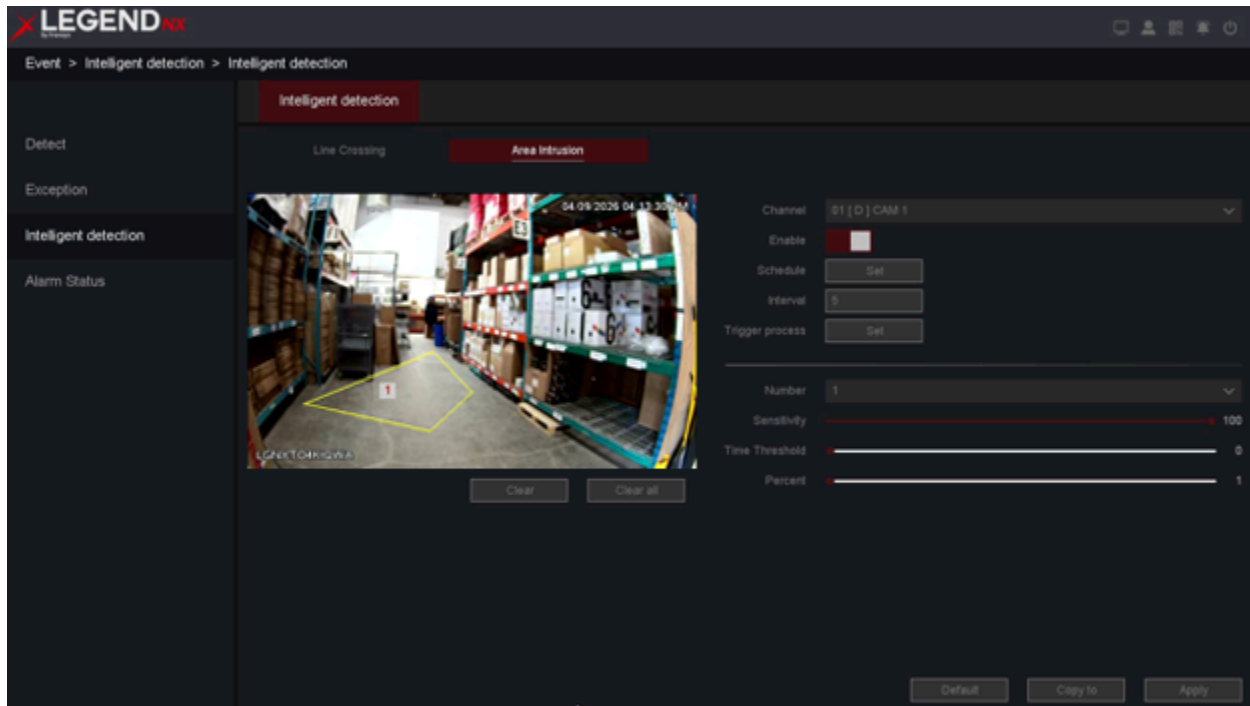

Figure 6-17 Area Intrusion

2. Select a camera.
3. Enable **Enable**.
4. Configure detection rules and detection areas.
 1. Select **Number** to set the arming area. Up to 4 arming areas can be configured. Click **Clear** or define four points in the preview window to clear or draw a quadrilateral detection area.
 2. Adjust **Sensitivity**. This determines the size of objects that can trigger an alarm. The higher the value, the easier it is to trigger detection. Range: 1–100.
 5. Configure the arming **Schedule**. Refer to **6.3.3 Configure Arming Schedule** for details.
 6. Configure the **Trigger Process**. Refer to **6.3.4 Configure Alarm Trigger Process** for details.
 7. Click **Apply**.

Note

Click **Clear All** to delete all alarm areas. You can also click **Clear** to delete individual areas.

6.3.3 Configure Alarm Trigger Process

The alarm trigger process is activated when an alarm or exception occurs.

Steps:

1. Click **Trigger Process**.

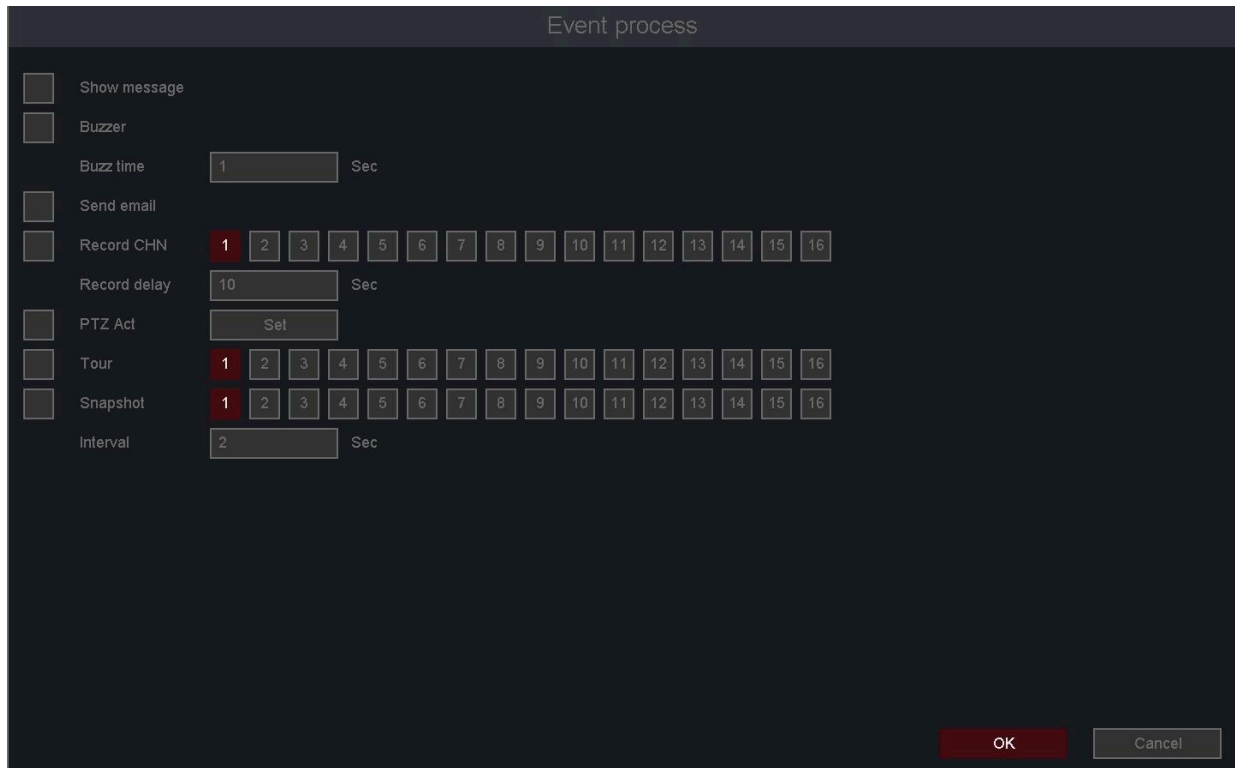

Figure 6-18 Trigger Process

2. Configure **Buzzer**, **Send Email**, **Record Channel**, etc.

Alarm Out

Triggers external alarm devices when an alarm occurs.

Buzzer & Buzz Time

Activates a buzzer sound when an alarm is triggered.

Send Email

Sends an email notification with alarm information when an alarm occurs.

Record Channel

Starts recording on the selected channel when an alarm is triggered and associates the recording for playback.

Record Delay

Specifies the duration of recording after the alarm ends.

PTZ Action

Triggers PTZ actions (e.g., Preset, Tour, Pattern) when smart events occur.

Tour

When an alarm is triggered, the system will cycle through the selected camera views.

Snapshot

Captures and saves an image for the channel when an alarm is triggered.

Interval

Defines the interval for continuous snapshot capture while the alarm is active.

3. Click **OK**.

Note

- For certain network cameras, you can configure alarm linkage actions such as audio or light alarms.
- Ensure the camera supports audio and light alarm linkage.
- Ensure the audio output and volume are properly configured.
- To configure audio and light parameters, log in to the network camera via a web browser.

7. Maintenance

7.1 System

1. Go to **Main Menu** → **System** → **Maintain** → **System**.

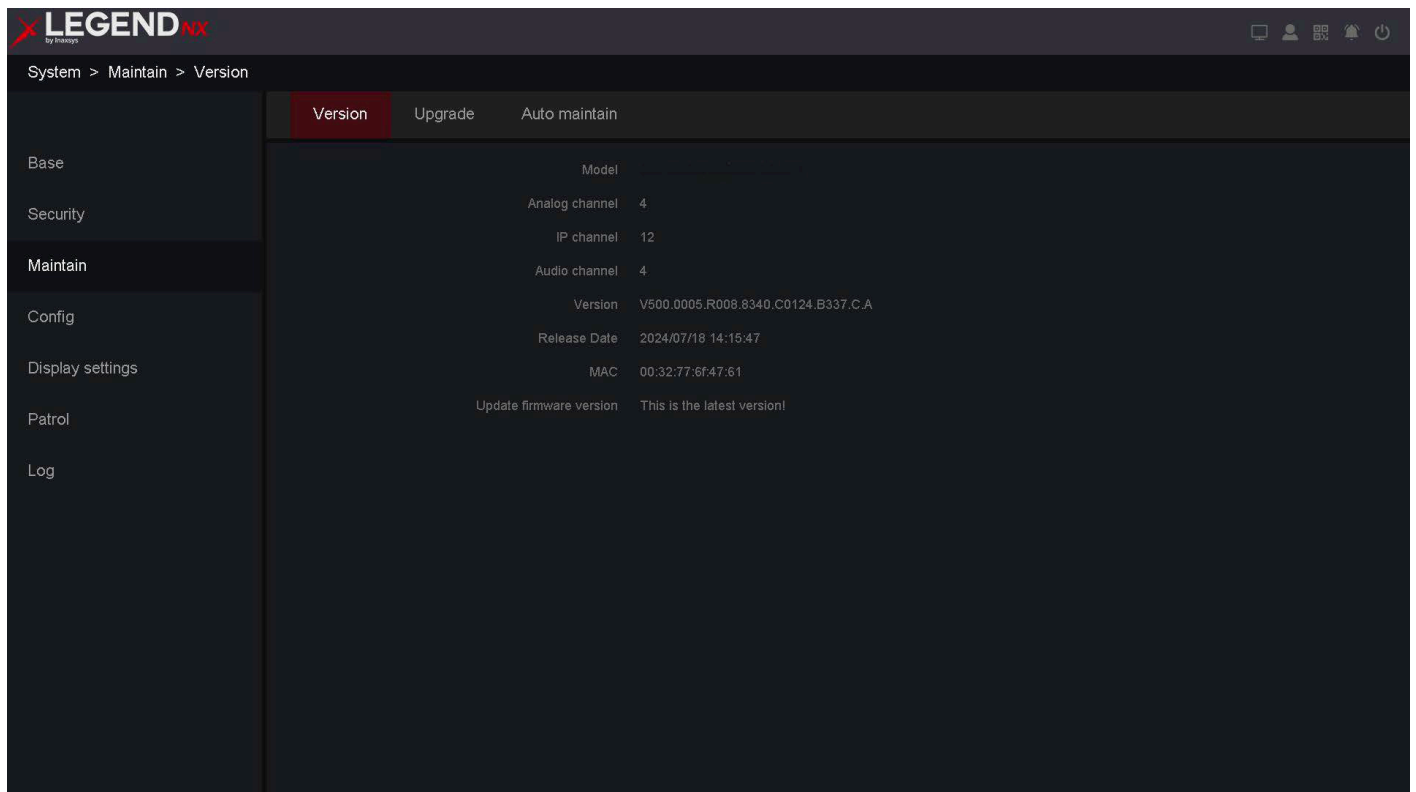

Figure 7-1 System

2. On this page, you can view the device version information.

Analog/IP/Audio Channel

Displays the number of analog, IP, and audio channels.

Alarm Input/Output

Displays the number of alarm input/output channels supported by the device.

Version

Displays the firmware version information.

Release Date

Displays the firmware release date.

MAC

Displays the MAC address of the device.

Update Firmware Version

Displays information about the available firmware version.

3. The system automatically checks whether the latest firmware is available.
4. If a new firmware version is available, click **Upgrade**.
 1. Select your USB flash drive from the **Device Name** drop-down list.
 2. Select the correct upgrade file.
 3. Click **Upgrade**.
 4. Click **OK**. The device will automatically restart after the upgrade is complete.

Note

Do not shut down or power off the device during the upgrade process.

7.2 Record

On this page, you can view the recording status of all channels, start or stop recording, configure stream type (video or video + audio), adjust frame rate and bit rate, set main/sub stream resolution for IP channels, and enable or disable the redundancy function.

Before You Start

Ensure that the recording schedule has been configured.

Steps:

1. Go to **Main Menu** → **Storage** → **Record**.

Chn	Status	Stream type	Frame rate(FPS)	Bit rate(Kb/S)	Resolution	Redundance
1	Open	Mixture	15	516	1920x1080/704x480	No
2	Stop	--	0	0	--/--	No
3	Stop	--	0	0	--/--	No
4	Stop	--	0	0	--/--	No
5	Open	Video	25	120	1920x1080/720x576	No
6	Open	Video	25	546	1920x1080/720x576	No
7	Open	Video	25	120	1920x1080/720x576	No
8	Open	Video	25	120	1920x1080/720x576	No
9	Stop	--	0	0	--/--	No
10	Stop	--	0	0	--/--	No
11	Stop	--	0	0	--/--	No
12	Stop	--	0	0	--/--	No
13	Stop	--	0	0	--/--	No
14	Stop	--	0	0	--/--	No
15	Stop	--	0	0	--/--	No
16	Stop	--	0	0	--/--	No

Figure 7-2 Record

7.3 Hard Disk Operation

The device supports HDD detection functions such as S.M.A.R.T. and Bad Sector Detection. S.M.A.R.T. (Self-Monitoring, Analysis and Reporting Technology) is a monitoring system used to detect and report various indicators of hard disk reliability, helping to anticipate potential failures.

Before You Start

Install at least one HDD in the video recorder.

Steps:

1. Go to **Main Menu** → **Storage** → **S.M.A.R.T.**
2. Select the HDD you want to test.
3. Select the self-test type: **Short Test** or **Extended Test**.

LEGEND by InKeys 🏠 👤 ⚙️ 🔔 🔌

Storage > S.M.A.R.T > S.M.A.R.T

S.M.A.R.T

Base
 Schedule
 Record
 Storage Mode
 S.M.A.R.T

No.	Status	Last test time	Temperature	Life time(hours)
[2] sda	Passed	2024/07/21 23:22:17	39°C	717

Test type: Short ▼

ID	Attribute name	Value	Worst	Threshold	Raw value
1	Raw_Read_Error_Rate	100	253	51	0
3	Spin_Up_Time	209	206	21	2550
4	Start_Stop_Count	100	100	0	22
5	Reallocated_Sector_Ct	200	200	140	0
7	Seek_Error_Rate	200	200	0	0
9	Power_On_Hours	100	100	0	717
10	Spin_Retry_Count	100	253	0	0
11	Calibration_Retry_Count	100	253	0	0
12	Power_Cycle_Count	100	100	0	21
192	Power-Off_Retract_Count	200	200	0	13
193	Load_Cycle_Count	200	200	0	8
194	Temperature_Celsius	108	99	0	39
196	Reallocated_Event_Count	200	200	0	0

Figure 7-3 Hard Disk Operation

4. Click **Start Selftest** to begin the S.M.A.R.T. HDD self-evaluation.
5. If the HDD is functioning properly, the status will display **Passed**. You can also pause or stop the test.

S.M.A.R.T

No.	Status	Last test time	Temperature	Life time(hours)
[2] sda	Passed	2024/07/22 03:46:16	39°C	717

Figure 7-4 Check Status

7.4 Network

You can view the current status parameters of all LAN connections on this screen.

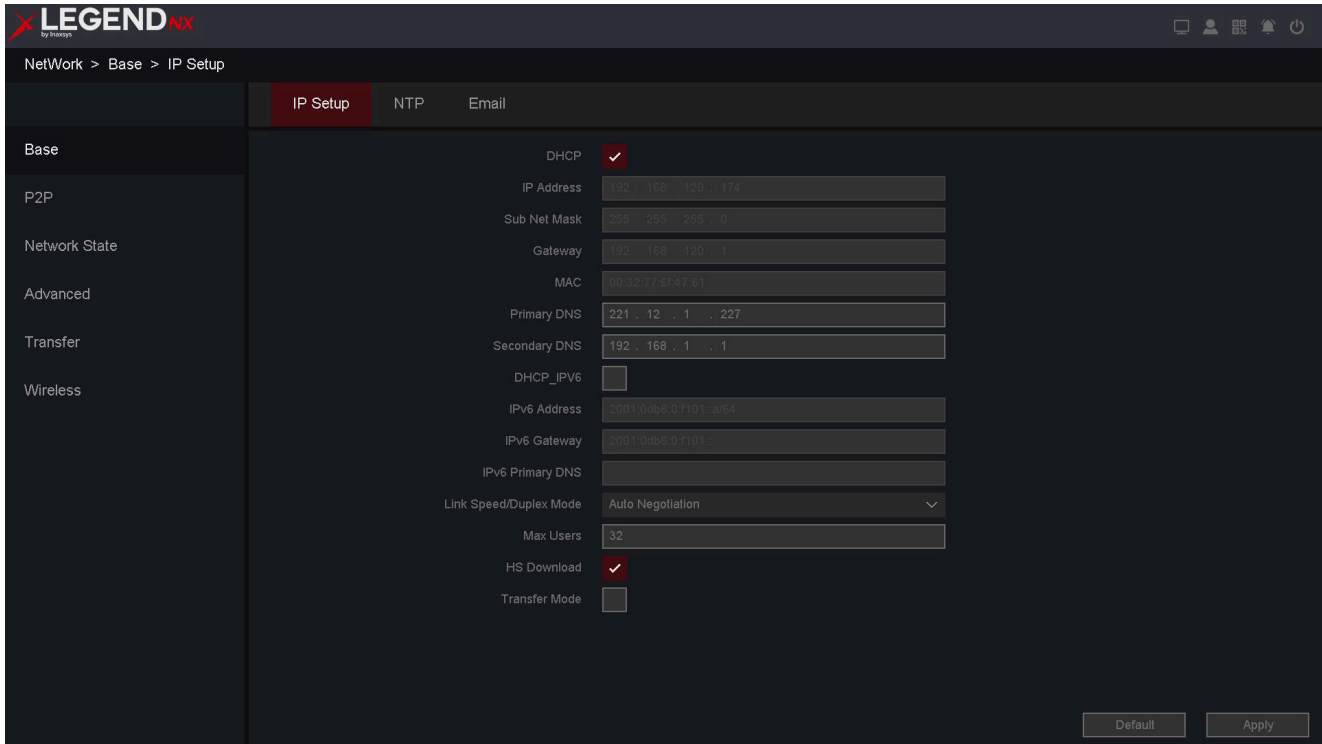

Figure 7-5 Network

7.5 Management

Steps:

1. Go to **Main Menu** → **System** → **Config** → **Default**.

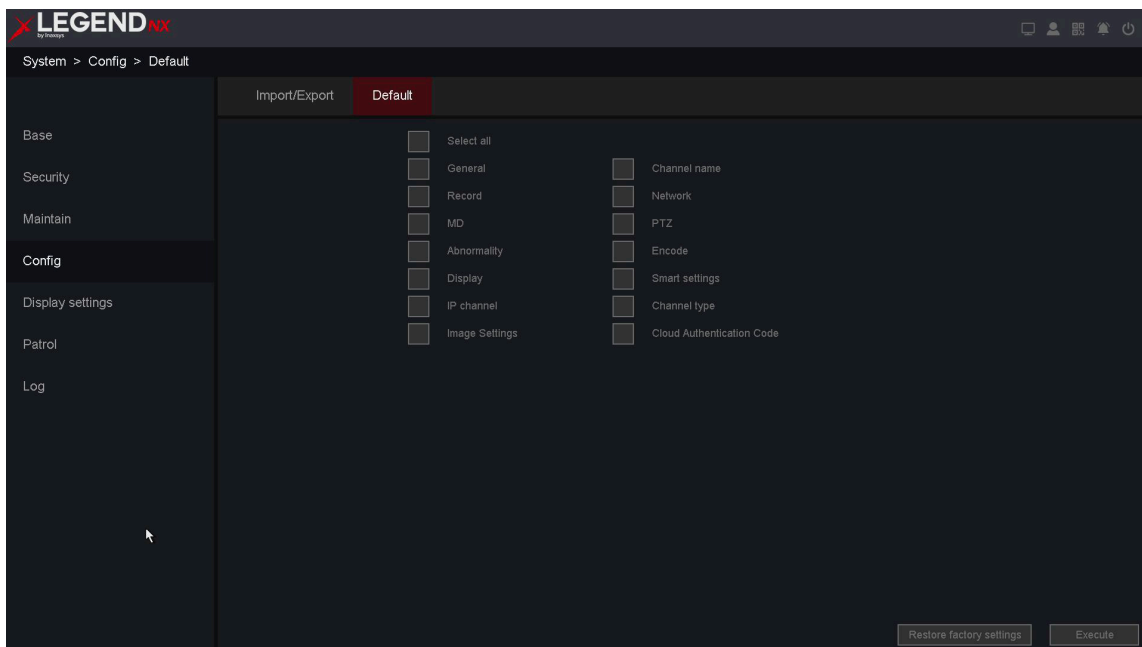

Figure 7-6 Default

2. Select the restore type.

Simple Restore

- Select the function items to restore, such as **General / Channel Name / Record / Network / MD / Alarm / Abnormality / PTZ / Display / Channel Type / Smart Settings / Image Settings / Cloud Authentication Code / Restore Inactivated Status**.
- Click **Execute**. The selected items will be restored to their default settings.
- Optional: Select **Select All** to restore all items to default settings.

Factory Defaults

Click **Restore Factory Settings** to reset all parameters to their factory default values.

3. After the restore operation is completed, the device will automatically reboot.

7.6 Log

The system stores operation, alarm, exception, and information logs of the video recorder. These logs can be viewed and exported at any time.

Steps:

1. Go to **Main Menu** → **System** → **Log**.

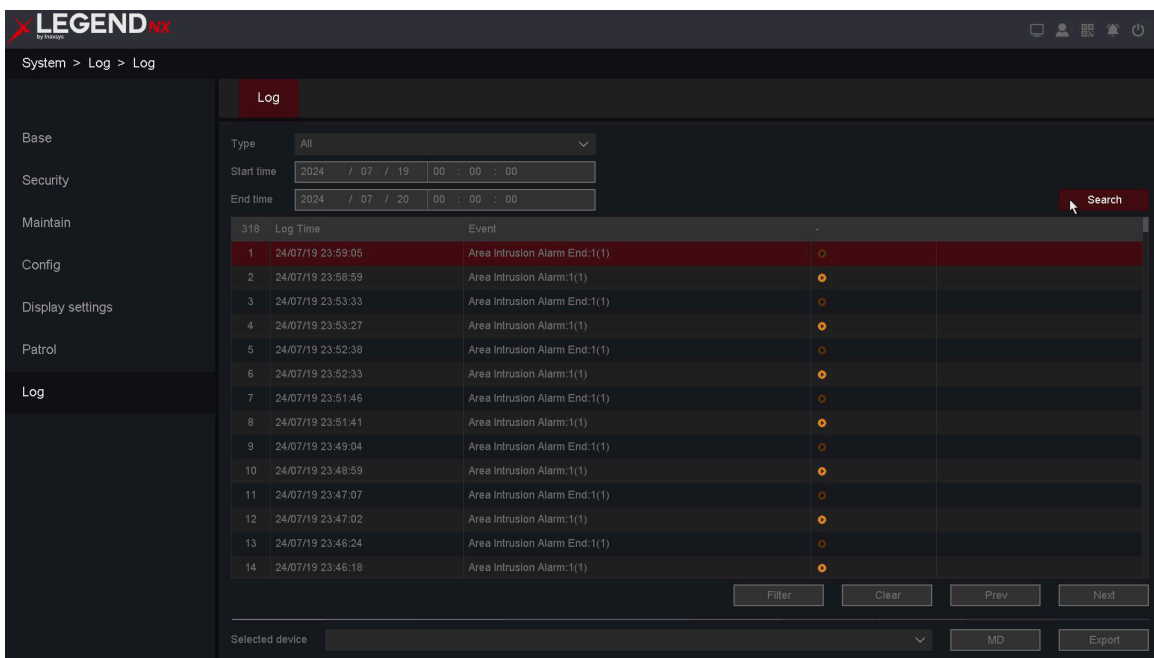

Figure 7-7 Log

2. Select the **Type** of log.
3. Select the desired time period.
4. Click **Search**.

Type

Available log types include **System, Config, Storage, Alarm, Record, Account, Clear, and Playback**.

Start Time / End Time

Set the time range for the log search.

Search

After setting the time range and log type, click **Search**. The device can store up to 4096 log entries.

Prev / Next

It can display up to 1000 logs per page. Click **Prev/Next** to view additional pages.

Filter

On this page, you can configure whether logs are overwritten when storage is full and select which types of operation logs to save.

MD

Detect the USB device.

Export

Export operation logs to a USB flash drive.

7.7 User

On the online user interface, you can view all currently connected users. If there are unknown users, you can disconnect them or block access for a specified period.

1. Go to **Main Menu** → **System** → **Security** → **Online Users**.

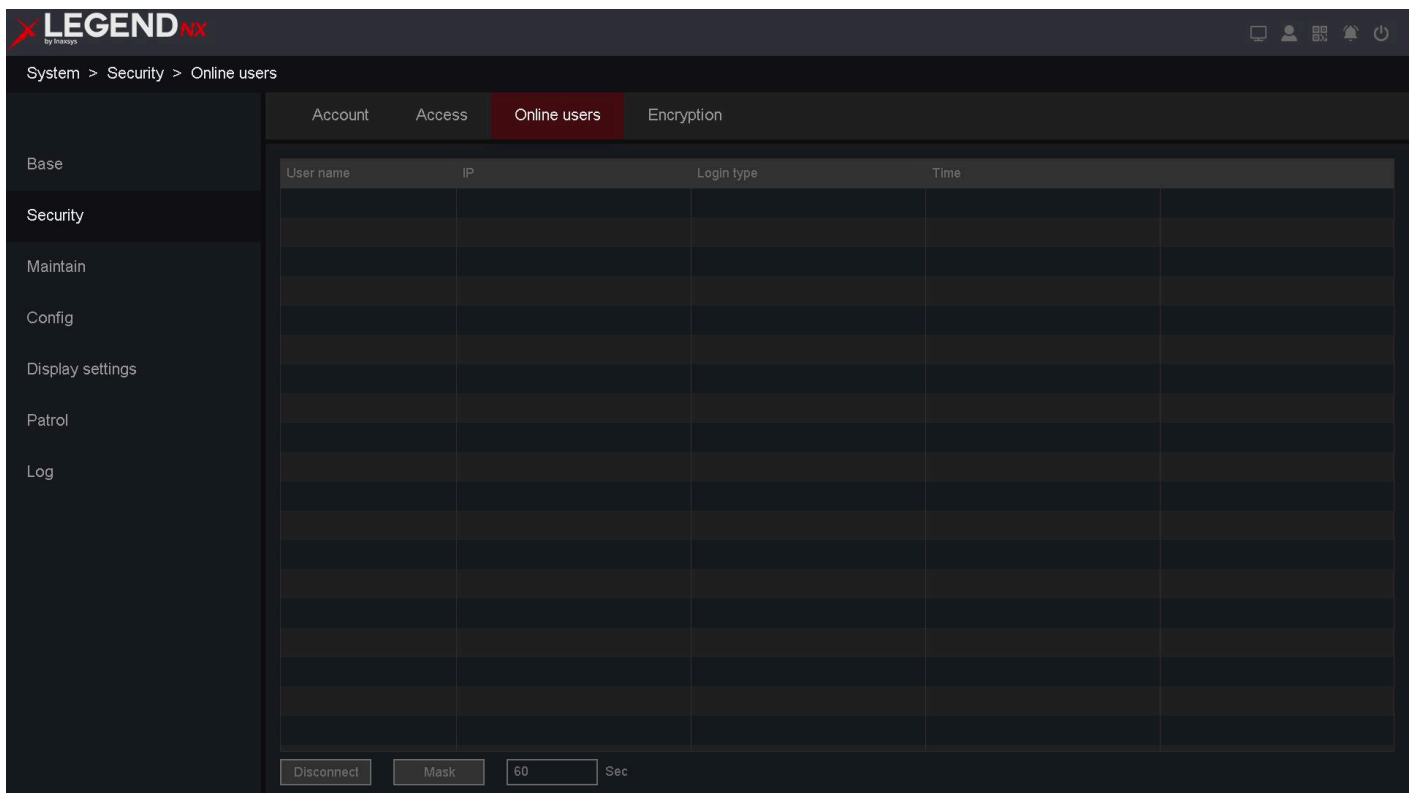

Figure 7-8 User

User Name

Displays the account used to log in to the UVR remotely.

IP

Displays the IP address of the remote device.

Login Type

Displays the type of remote connection.

Time

Displays the login time of the online user.

Disconnect

Disconnects the selected user. Disconnected users may reconnect automatically after a short time.

Block

Shield the connected user for a specified period. The remote user will be unable to reconnect during this time.

7.7.1 Storage

Initialize HDD

A newly installed hard disk drive (HDD) must be initialized before it can be used to store video and data.

Before You Start

Install at least one HDD in the video recorder. For detailed instructions, refer to **1.3 HDD Installation**.

Steps:

1. Go to **Main Menu** → **Storage** → **Base**.

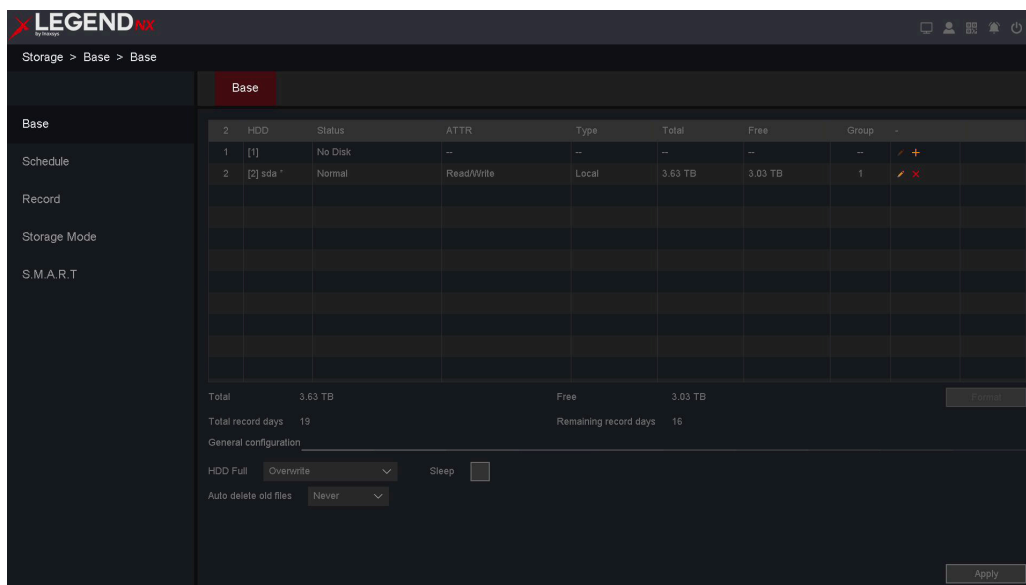

Figure 7-9 HDD Management

2. Select an HDD.
3. Click **Format**.
4. Click **OK** to continue.

Note

To repair an HDD that fails to function as a database, contact professional technical support for assistance.

HDD Management

This page displays information about the installed hard drives, including disk number, status, attributes, type, total and available capacity, group assignment, as well as edit and delete options.

HDD

Displays the HDD serial number, such as “[1] sda” or “[2] sdb”.

Status

Displays the HDD status: “Unformatted”, “Normal”, or “No Disk”.

ATTR

HDD supports three attribute types: **Read/Write**, **Read Only**, and **Redundant**.

Type

Displays the HDD connection type.

Total

Displays the total storage capacity of the HDD.

Free

Displays the remaining available capacity of the HDD.

Group

Displays the group to which the HDD belongs.

Delete

Uninstalls the HDD.

Add

Adds the HDD from an uninstalled state.

Format

Formats the HDD manually.

Steps:

1. Click the **Edit** button for the HDD. The interface is shown below.

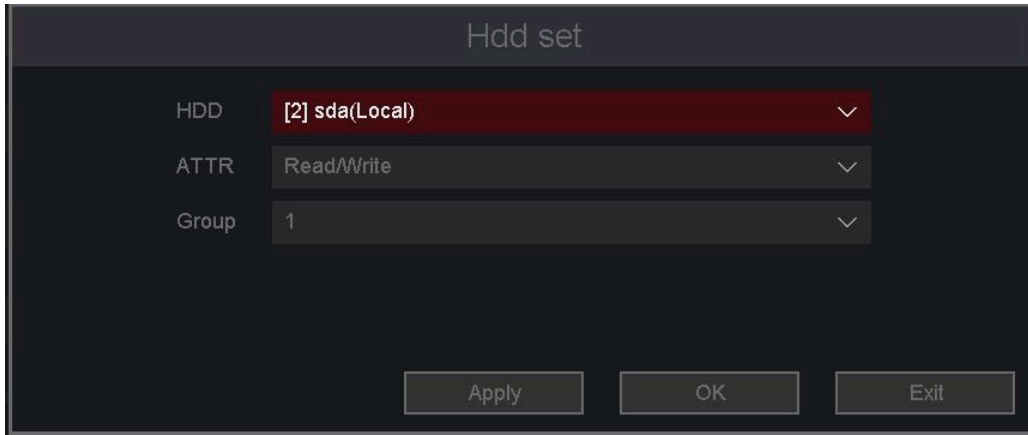

Figure 7-10 Edit

2. Configure the remaining parameters as required.
3. Click **OK**.

Advanced

On this page, you can configure the full-disk handling strategy: **Stop Record** or **Overwrite**.

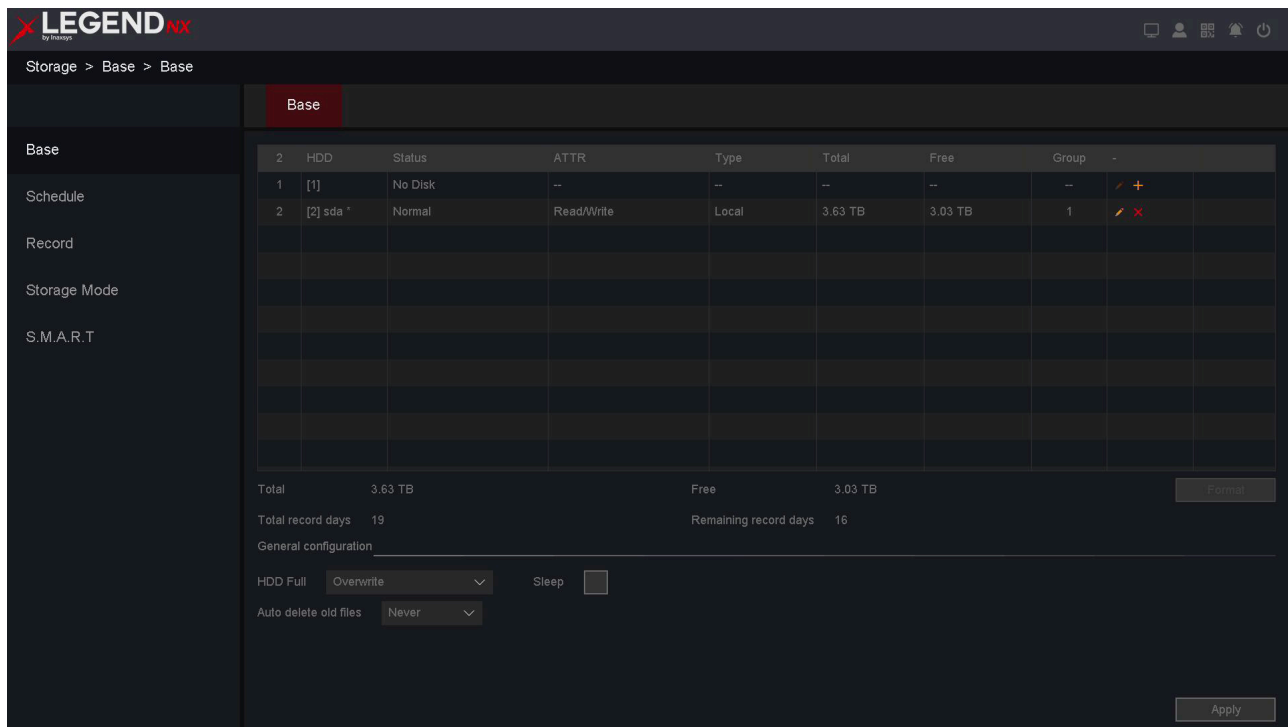

Figure 7-11 Advanced

HDD Full

- **Stop Record:** When the HDD is full, the video recorder stops writing data.
- **Overwrite:** When the HDD is full, the video recorder continues writing new files by deleting the oldest files.

Auto-Delete Old Files

Supports two modes: **Never** and **Custom**. In **Custom** mode, you can set the auto-delete period from 1 to 30 days.

Sleep Mode

If the HDD remains idle for an extended period, it will enter sleep mode.

7.7.2 Configure Recording Schedule

Configure the recording schedule by setting the related parameters. The video recorder will automatically start and stop recording according to the configured schedule. Before performing these operations, ensure that the HDD has been installed and formatted. If not, install and initialize the HDD first. For details, refer to **6.4.1 Storage**.

Configure Recording

Steps:

1. Go to **Main Menu** → **Storage** → **Schedule**.

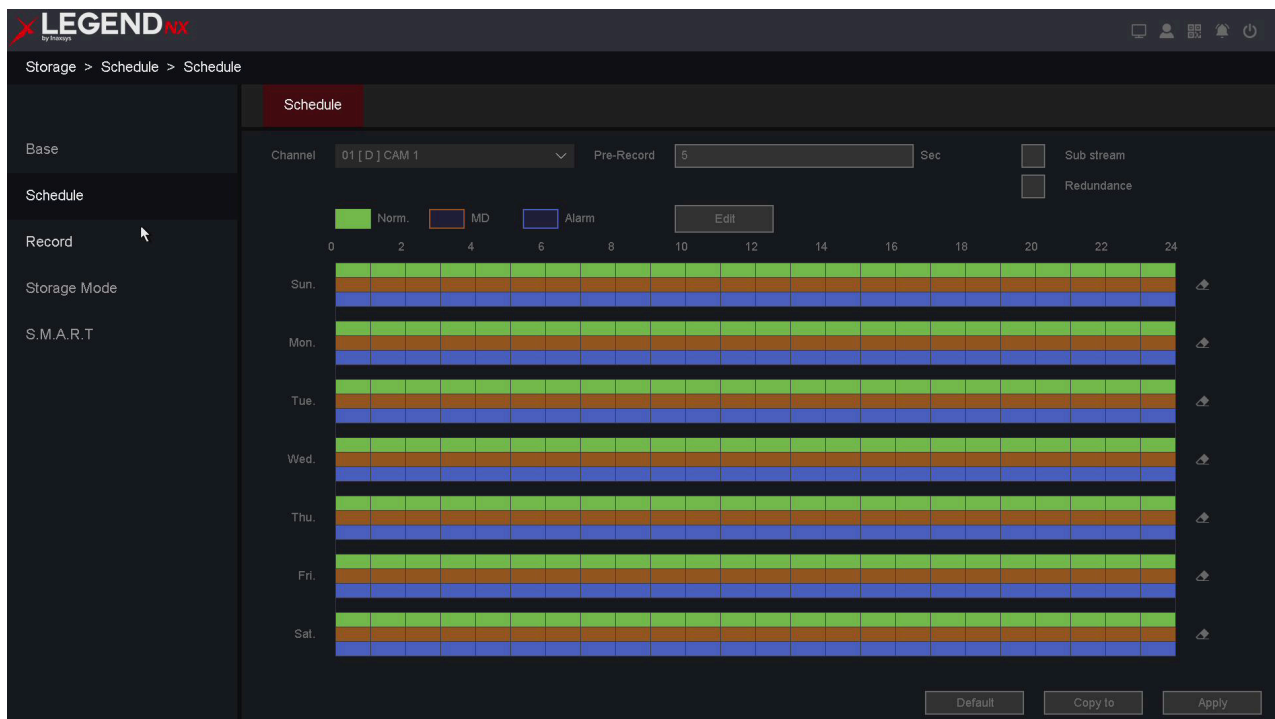

Figure 7-12 Schedule

2. Select the channel.
3. Set **Pre-Record**.
The duration of pre-recording for generated video files. Range: 0–30 seconds.
4. Select **Main Stream** recording or **Sub Stream** recording.
Some devices with fewer than 16 channels support dual-stream recording.
5. Configure the recording schedule.
6. Click **Apply**.

Note

- **Redundancy**: Recordings will be backed up to a redundant HDD if a redundant HDD device is installed in the system.
- If multiple channels are configured with the pre-record function, the pre-record time may be less than 30

seconds (maximum value). This is because pre-recording consumes system resources, and the system will automatically adjust the duration to support multiple channels simultaneously.

Edit Schedule

OPTION 1:

Click the **Edit** button to enter the editing interface and configure the recording schedule.

Week day	Schedule 1	Schedule 2	Schedule 3	Schedule 4	Schedule 5	Schedule 6	Norm.	MD	Alarm
Sun	00 : 00 - 24 : 00	00 : 00 - 24 : 00	00 : 00 - 24 : 00	00 : 00 - 24 : 00	00 : 00 - 24 : 00	00 : 00 - 24 : 00	<input checked="" type="checkbox"/>	<input checked="" type="checkbox"/>	<input checked="" type="checkbox"/>
							<input type="checkbox"/>	<input type="checkbox"/>	<input type="checkbox"/>
							<input type="checkbox"/>	<input type="checkbox"/>	<input type="checkbox"/>
							<input type="checkbox"/>	<input type="checkbox"/>	<input type="checkbox"/>
							<input type="checkbox"/>	<input type="checkbox"/>	<input type="checkbox"/>
							<input type="checkbox"/>	<input type="checkbox"/>	<input type="checkbox"/>

Apply to

All Sun. Mon. Tue. Wed.
 Thu. Fri. Sat.

OK Cancel

Figure 7-13 Edit Schedule

Week Day

Select the day for the schedule, from Sunday to Saturday.

Schedule 1–6

Defines the recording time periods. Up to 6 time slots can be configured per day.

Normal

Standard recording mode for continuous video.

MD

Motion Detection recording mode. Recording is triggered by video or audio detection events.

Alarm

Alarm recording mode. Recording is triggered by external alarm inputs or network alarm events.

Steps:

1. Click **Edit**.
2. Select the **Week Day** (Sunday to Saturday).
3. Set the desired recording time period.
4. Select **Alarm**, **MD**, or **Normal** as the recording type.
5. Click **OK**.

Note

You can select **All** to apply the schedule to all days, or select multiple days as needed. If **Normal**, **MD**, and **Alarm** are selected simultaneously, the recording priority is: **Alarm > MD > Normal**. If multiple events occur at the same time, the recording type will follow this priority, with **Alarm** taking precedence.

OPTION 2:

You can also edit the schedule directly from the graphical configuration interface, as shown below.

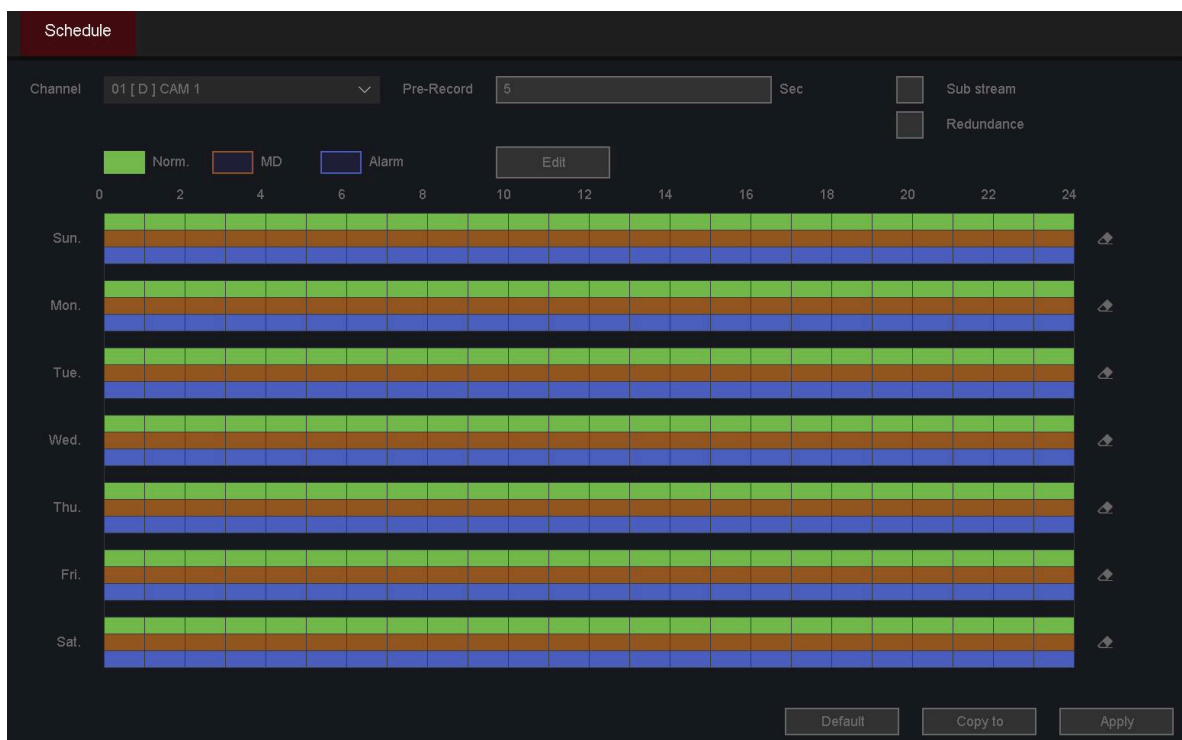

Figure 7-14 Edit Schedule

Steps:

1. Select one of **Normal**, **MD**, or **Alarm** in the upper-left corner.
2. Click and hold the left mouse button, then drag across the corresponding timeline bar.
3. When **Normal** is selected, click and drag to configure the green segments of the timeline. The first drag action selects a segment, and the next drag action clears it, and so on.
4. Click the **Clear** icon  to reset the entire schedule bar at once.
5. After completing all settings, click **Apply**.
6. **Optional:** Click **Copy to** to copy the current channel settings to other channels.



Figure 7-15 Copy to

Note

Click **Default** to restore all settings to their default values.

Configure MD Recording

You can configure recording triggered by **Motion Detection**, **Perimeter Protection**, **Behavior Analysis**, **Face Detection**, **Video Diagnosis**, and **Audio Detection**.

Steps:

1. Select **MD** in the upper-left corner.
2. Click and hold the left mouse button, then drag across the yellow timeline bar to select or clear segments.
3. **Optional:** Click the **Clear** icon  to reset the entire schedule bar at once.
4. After completing all settings, click **Apply** to activate them.
5. **Optional:** Click **Copy to** to copy the current channel settings to other channels.

Configure Alarm Recording

You can configure recording triggered by **Alarm I/O** and **System Alert** events.

Steps:

1. Select **Alarm** in the upper-left corner.
2. Click and hold the left mouse button, then drag across the blue timeline bar to select or clear segments.
3. **Optional:** Click the **Clear** icon  to reset the entire schedule bar at once.
4. After completing all settings, click **Apply** to activate them.
5. **Optional:** Click **Copy to** to copy the current channel settings to other channels.

8. Alarm Center

When events occur, you can view their details in the Alarm Center.

8.1 Alarm Center

All alarm events are displayed here when they occur.

Steps:

1. Go to **Main Menu** → **Event** → **Alarm Status**.

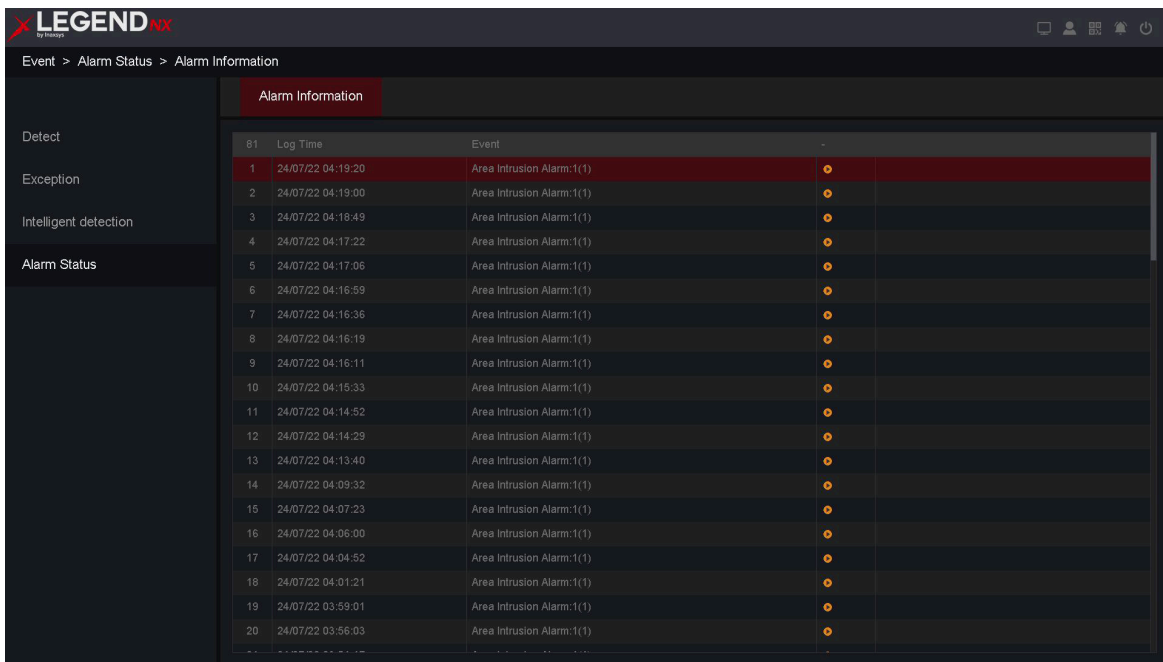

The screenshot shows the LEGEND NX Alarm Center interface. The breadcrumb navigation is "Event > Alarm Status > Alarm Information". The left sidebar has a "Detect" section with sub-items: "Exception", "Intelligent detection", and "Alarm Status". The main area displays a table of alarm events.

81	Log Time	Event		
1	24/07/22 04:19:20	Area Intrusion Alarm:1(1)	○	
2	24/07/22 04:19:00	Area Intrusion Alarm:1(1)	○	
3	24/07/22 04:18:49	Area Intrusion Alarm:1(1)	○	
4	24/07/22 04:17:22	Area Intrusion Alarm:1(1)	○	
5	24/07/22 04:17:06	Area Intrusion Alarm:1(1)	○	
6	24/07/22 04:16:59	Area Intrusion Alarm:1(1)	○	
7	24/07/22 04:16:36	Area Intrusion Alarm:1(1)	○	
8	24/07/22 04:16:19	Area Intrusion Alarm:1(1)	○	
9	24/07/22 04:16:11	Area Intrusion Alarm:1(1)	○	
10	24/07/22 04:15:33	Area Intrusion Alarm:1(1)	○	
11	24/07/22 04:14:52	Area Intrusion Alarm:1(1)	○	
12	24/07/22 04:14:29	Area Intrusion Alarm:1(1)	○	
13	24/07/22 04:13:40	Area Intrusion Alarm:1(1)	○	
14	24/07/22 04:09:32	Area Intrusion Alarm:1(1)	○	
15	24/07/22 04:07:23	Area Intrusion Alarm:1(1)	○	
16	24/07/22 04:06:00	Area Intrusion Alarm:1(1)	○	
17	24/07/22 04:04:52	Area Intrusion Alarm:1(1)	○	
18	24/07/22 04:01:21	Area Intrusion Alarm:1(1)	○	
19	24/07/22 03:59:01	Area Intrusion Alarm:1(1)	○	
20	24/07/22 03:56:03	Area Intrusion Alarm:1(1)	○	

Figure 8-1 Alarm Center

Alert

Displays system abnormal alarm messages.

Basic Event

Displays general event alarm messages.

Smart Event

Displays intelligent event alarm messages.

One-key Disarming

Enable or disable all event alarms with a single click.

Set

Configure which specific events will display alarm messages.

Table 8-1 Event Classification

Item	Description
Alert	No Writable Disk, Disk Error, Disk Full, Network Disconnect, IP Conflict
Basic Event	Motion Detection, Video Cover, Video Loss, Camera I/O, Blurred Detection, Scene Change Detection, Audio Exception Detection
Smart Event	Line Crossing, Area Intrusion, Region Entrance, Region Exit, Fast Moving, Unattended Object, Object Missing, Face Detection, Loitering Detection, Parking Detection, People Gathering

9. Configuration (Advanced Mode)

9.1 System Settings

9.1.1 General Configuration

Basic Setting

You can configure the Language, Time Zone, System Time, Time Format, DST, Auto Logout, Startup Wizard, Device No., Host Name, and Preview Strategy.

Steps:

1. Go to **Main Menu** → **System** → **Base** → **Base**.
2. Configure the parameters as required. For details, refer to **6.1.1 General Configuration**.

DST Setting

DST (Daylight Saving Time) refers to the period of the year when clocks are set forward by one hour. In some regions worldwide, this results in extended daylight in the evening during warmer months.

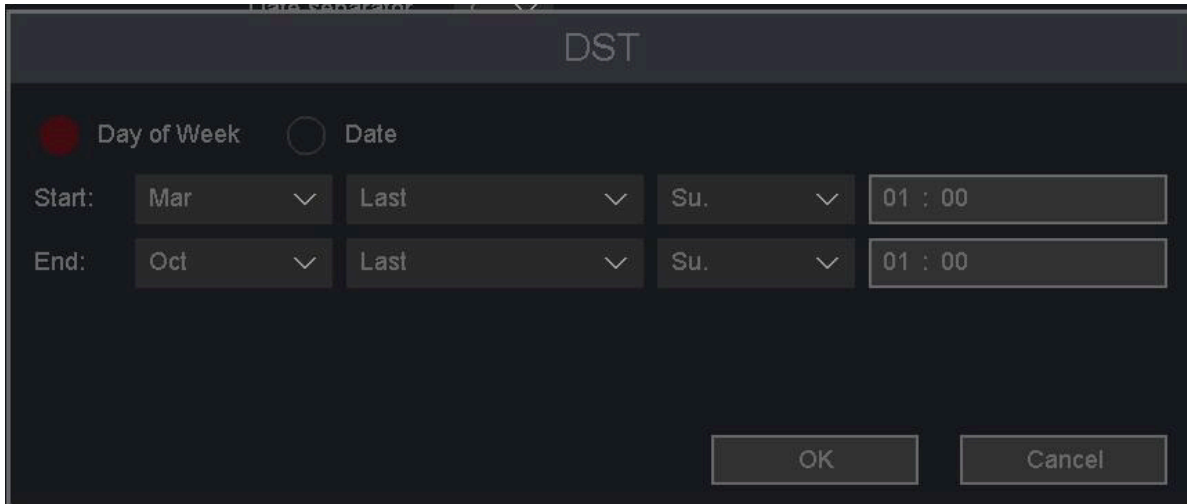

Figure 9-1 DST Setting

9.1.2 View Setting

Display

1. Go to **Main Menu** → **System Settings** → **Display Settings** → **Display**.

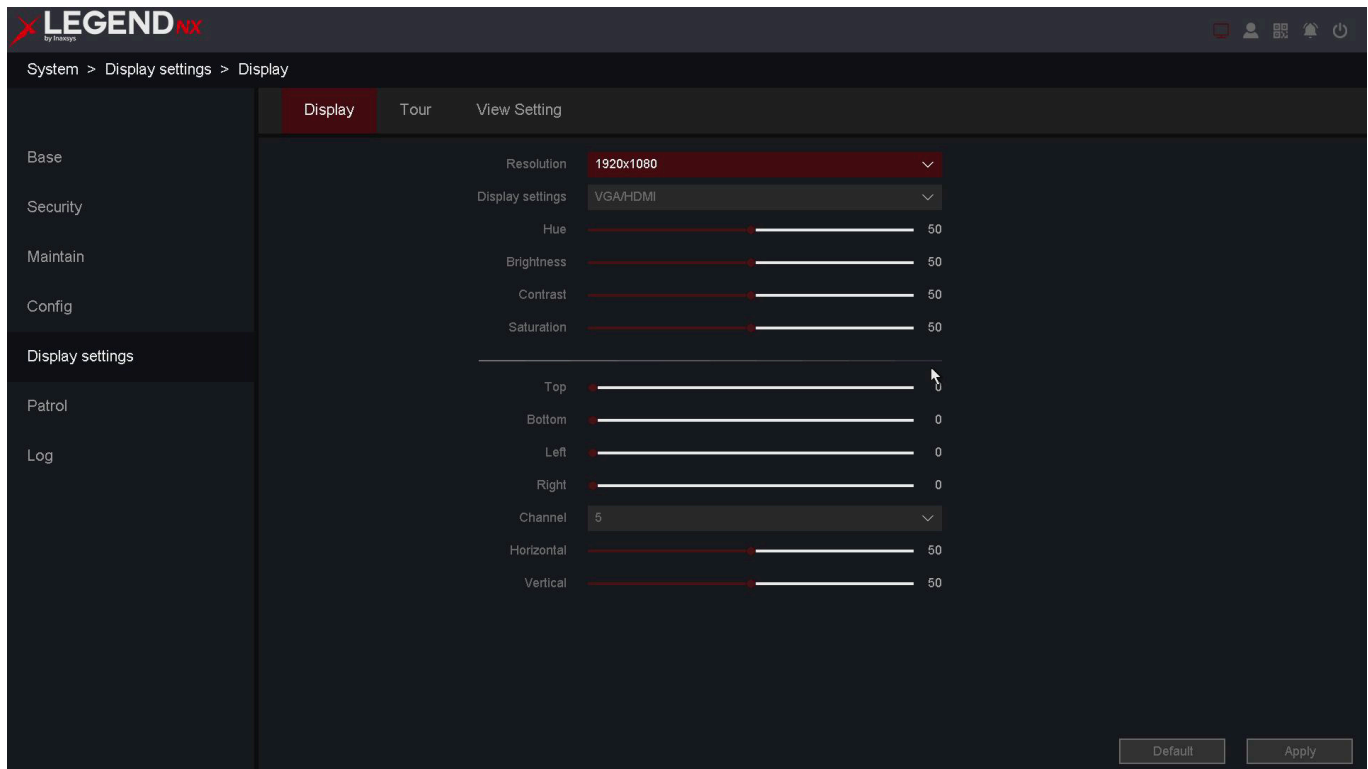

Figure 9-2 Output adjust

Resolution

Select the appropriate resolution for the menu output.

Tour

In this section, you can configure the patrol display for monitoring.

1. Go to **Main Menu** → **System Setting** → **Display Settings** → **Tour**.

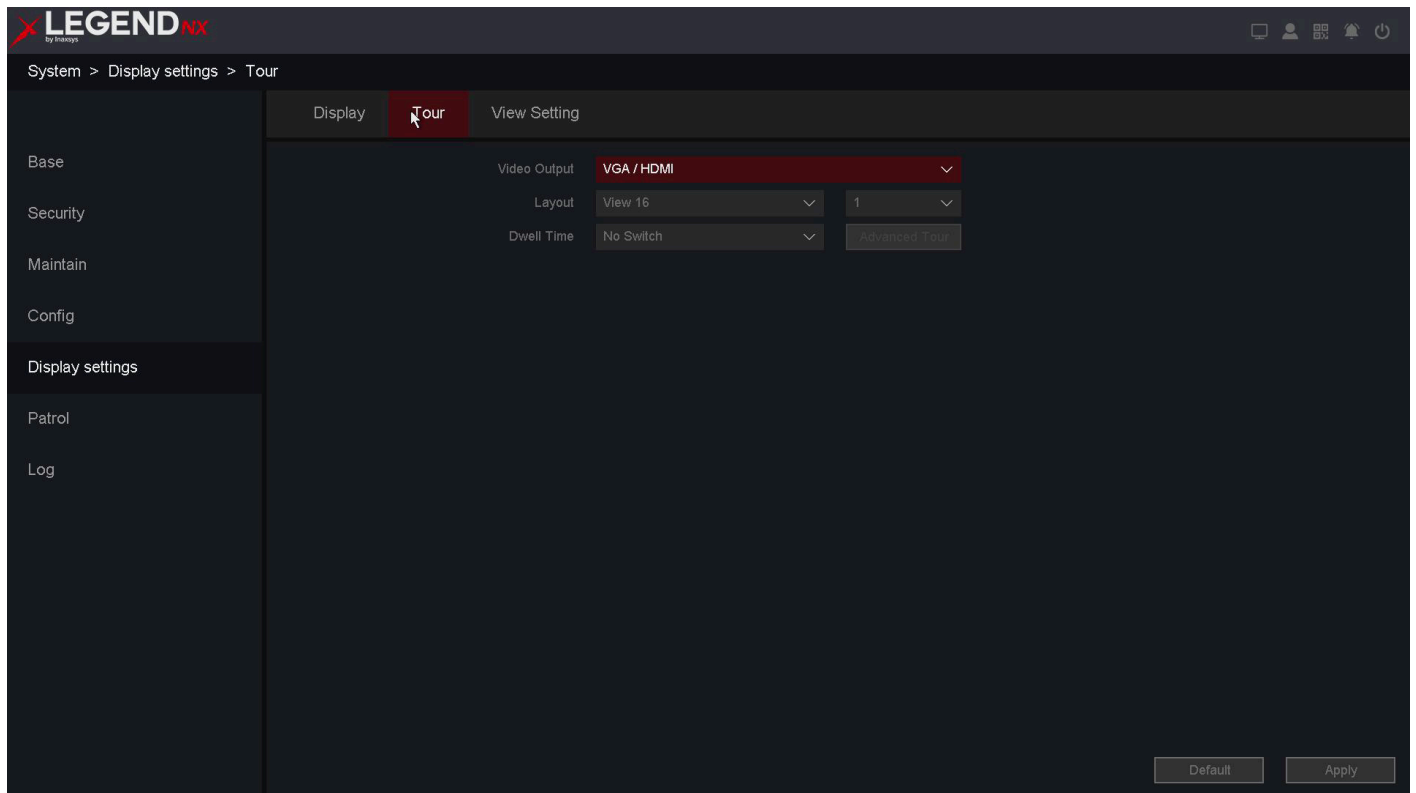

Figure 9-3 Tour

Video Output

Set the video output mode to **VGA/HDMI** or **CVBS**.

Layout

Configure the number of channels and channel groups for preview. For example, on a 16-channel UVR:

- Selecting **View 6-1** displays channels 1–6.
- Selecting **View 6-2** displays channels 7–12, and so on.

Dwell Time

Set the duration (in seconds) for switching between channels when auto-switch is enabled in Live View.

2. Click **Apply** after completing the configuration.

View Settings

In this section, you can configure the monitor patrol display.

1. Go to **Main Menu** → **System Setting** → **View Setting** → **View Settings**.

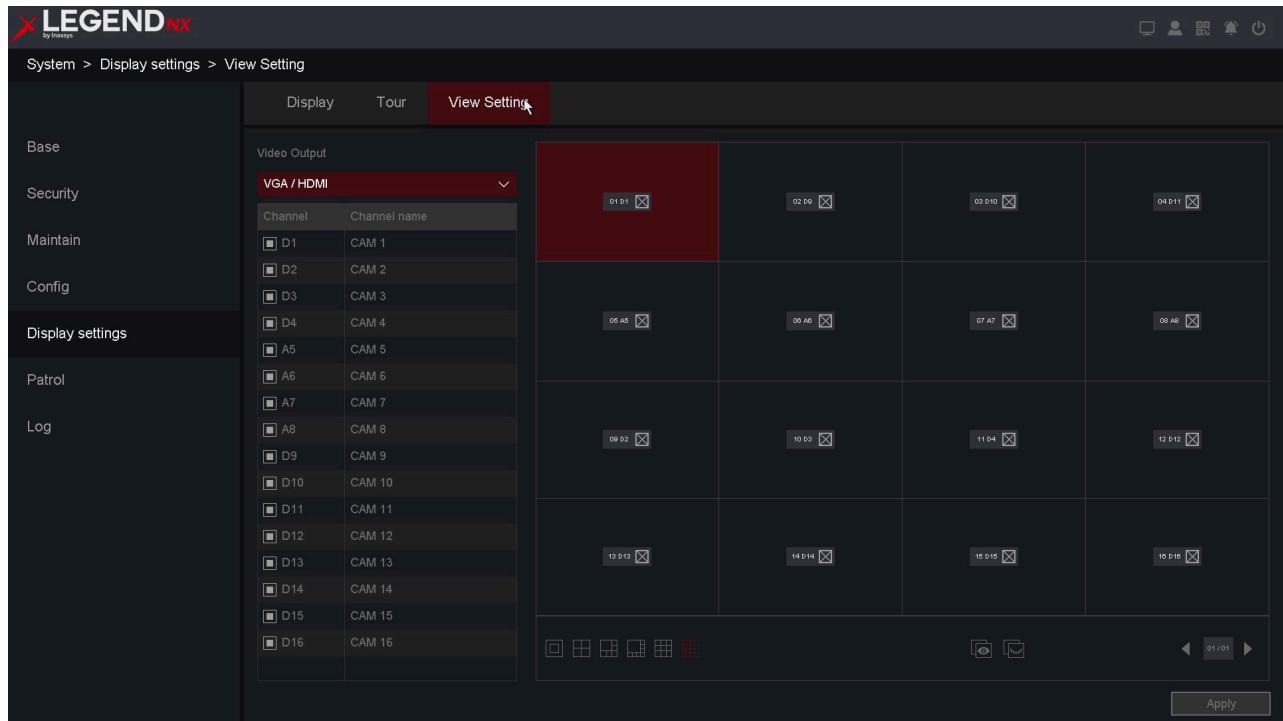





Figure 9-4 View Settings

2. Click a window to select it, then double-click a camera name in the channel list that you want to display.
3. You can also click the  icon to display the configured channels for each screen, and click the cancel icon  to remove configured channels from the screen. Click the  or  arrow to switch between pages.
4. Click **Apply**.

9.1.3 Account

Steps:

1. Go to **Main Menu** → **System** → **Security** → **Account**.

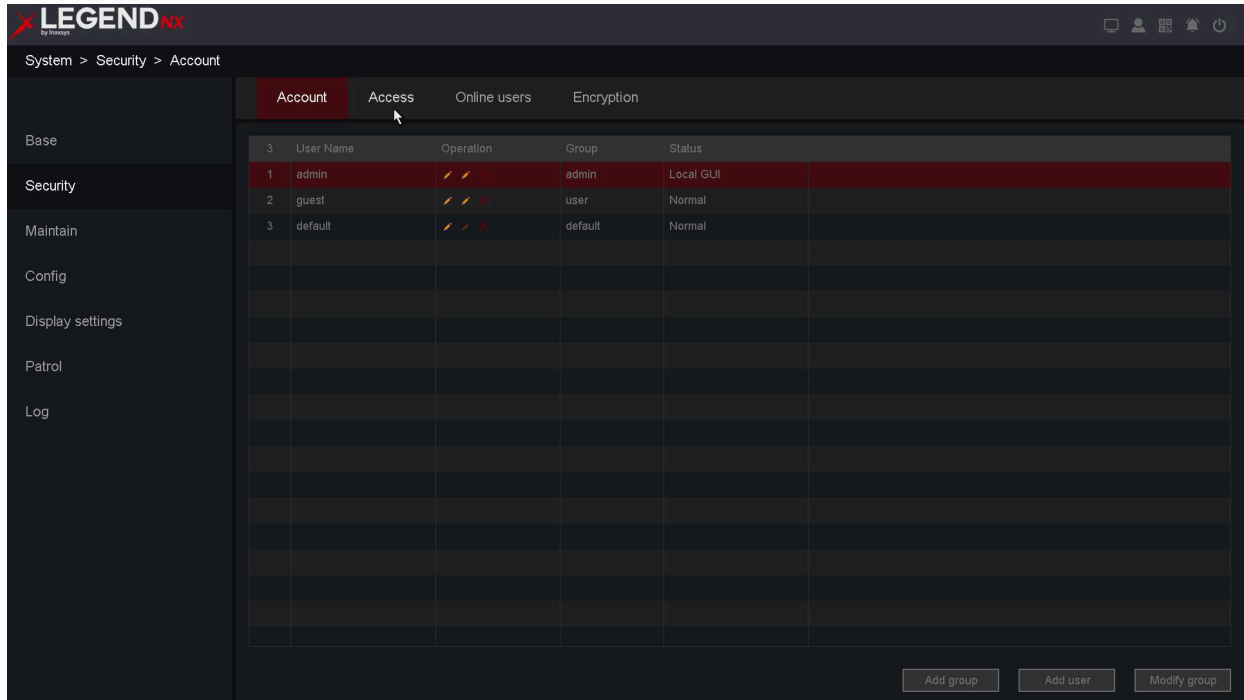

Figure 9-5 Account

Add Group

Add a user group and assign permissions. Available permissions include: Control panel, Shutdown device, Backup, Local playback, Monitor, and more.

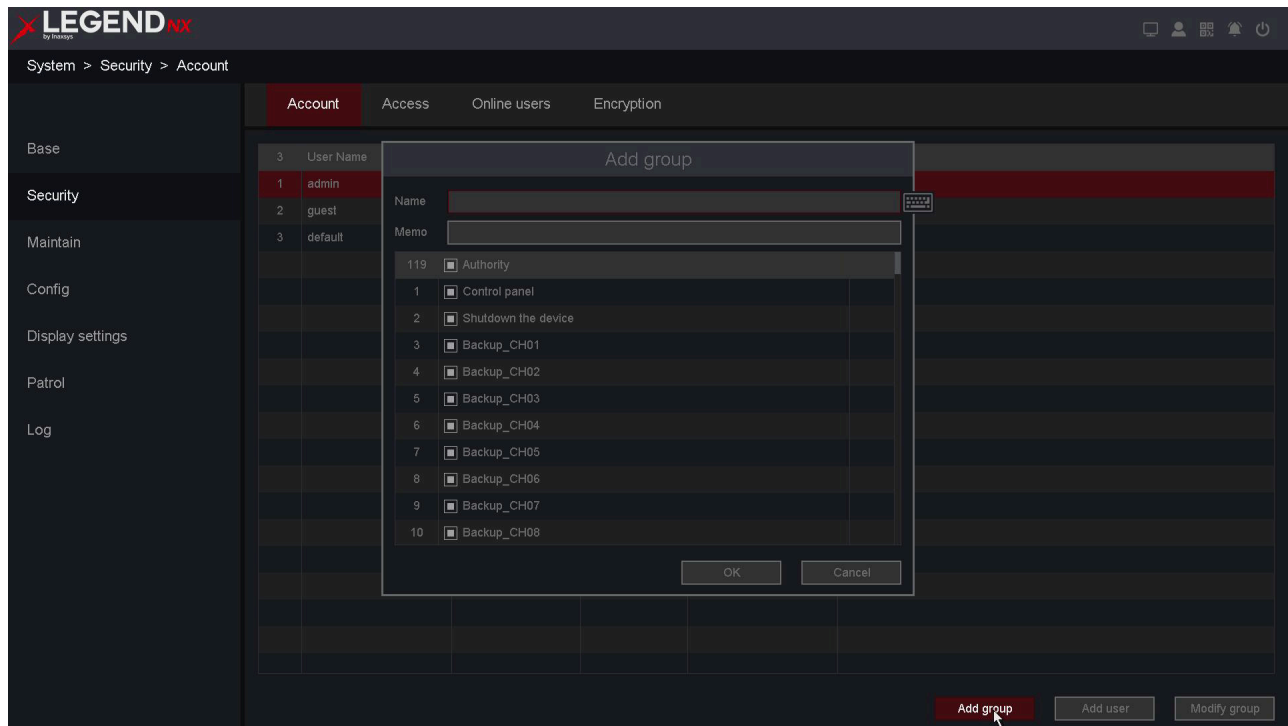

Figure 9-6 Add Group

Modify Group

Modify the attributes of existing groups and configure parameters as required.

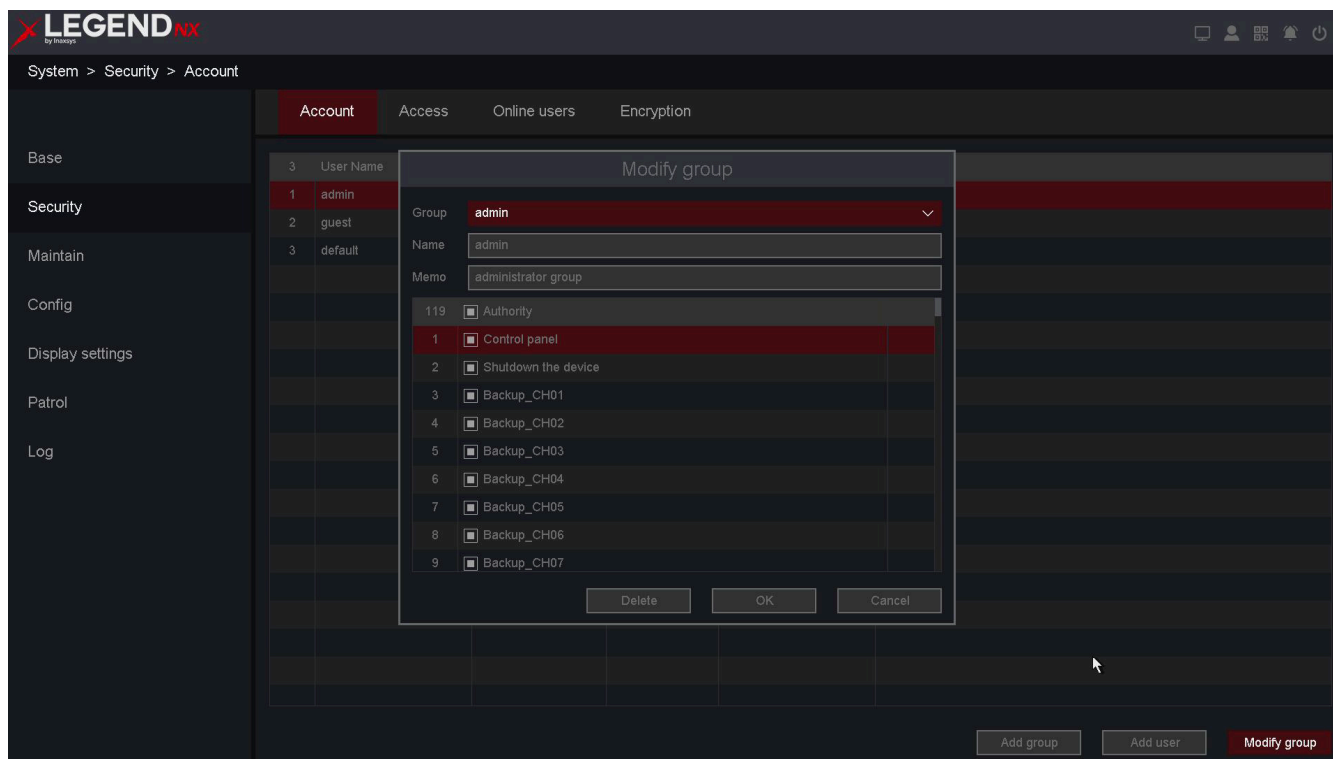

Figure 9-7 Modify Group

Add user, modify user, change password, and configure password recovery settings. For details, refer to **6.1.2 Account**.

Note

- The maximum length for user and user group names is 64 bytes. Only letters and numbers are allowed; other characters are not supported.
- User management includes groups and users. Each user must belong to one group.

9.2 Network

9.2.1 IP Address

TCP/IP must be properly configured before operating the video recorder over the network. On this page, you can set the device IP address, gateway, and DNS, as well as view the MAC address. If the UVR has two Ethernet ports, it can connect to two network segments, and one can be set as the default route.

Steps:

1. Go to **Main Menu** → **Network** → **IP Address** → **TCP/IP**.
2. For general settings, refer to **6.2.1 General - TCP/IP** for details.
3. Configure other network parameters as required.

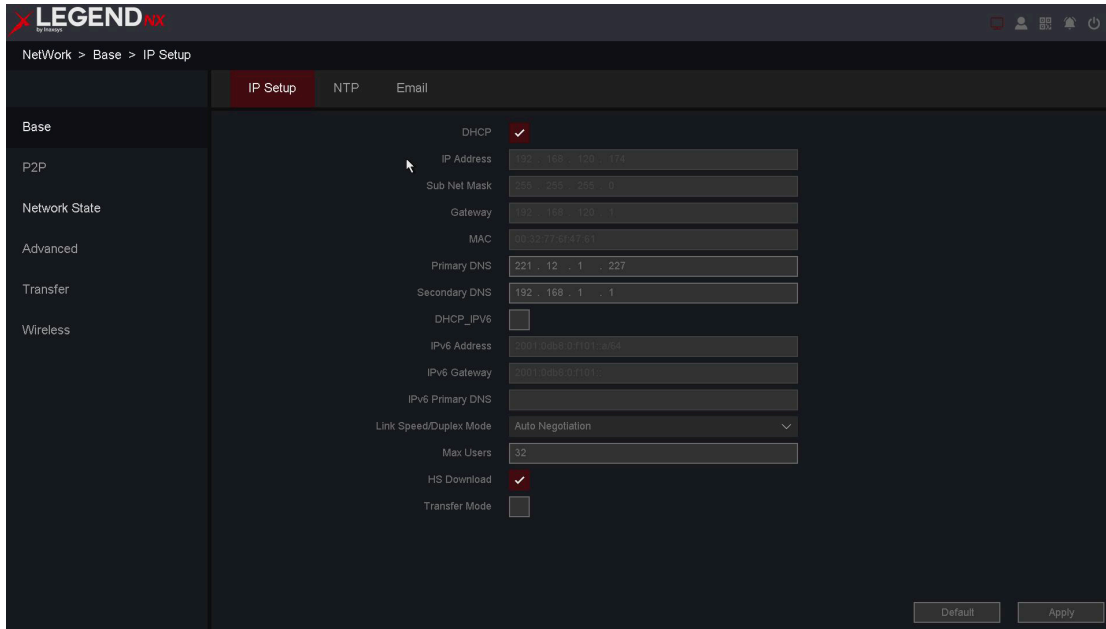

Figure 9-8 TCP/IP

DHCP

If a DHCP server is available, enable **DHCP** to automatically obtain an IP address and other network settings from the server.

MAC

The physical address of the UVR.

DNS Setup

Enable **Auto DNS** to automatically obtain DNS settings. The Domain Name Server (DNS) translates domain names into IP addresses and includes both primary and secondary DNS.

Link Speed/Duplex Mode

Available modes include: 10 Mbps Half Duplex, 10 Mbps Full Duplex, 100 Mbps Half Duplex, 100 Mbps Full Duplex, and Auto Negotiation.

Max Users

The maximum number of users who can simultaneously access the UVR is 32 by default.

HS Download

Enables high-speed downloading over the network.

Transfer Mode

Three modes are available: Quality Preferred, Fluency Preferred, and Adaptive. The video stream automatically adjusts based on the selected mode. Adaptive provides a balance between image quality and smooth playback. Fluency Preferred and Adaptive are effective only when the sub-stream is enabled; otherwise, Quality Preferred is used.

4. Click **Apply**.

9.2.2 Platform Access

P2P

Go to **Main Menu** → **Network** → **Base** → **P2P**. Refer to **6.2.2 P2P** for details.

Email

Go to **Main Menu** → **Network** → **Base** → **Email**. Refer to **6.2.3 Email** for details.

9.2.3 Advanced

FTP

You can upload recorded files to an FTP server by configuring the FTP settings. This allows uploads based on recording type and recording time.

Before You Start

Ensure that your FTP server is operating properly and can receive uploaded files.

Steps:

1. Go to **Main Menu** → **Network** → **Advanced** → **FTP**.
2. Configure each parameter of the FTP service.

FTP Setting

The configuration includes **Video FTP** and **Picture FTP**. You can set the server IP, port, username, password, directory, and file length. The **Anonymous** option is also available. Use **FTP Test** to verify whether the configuration is successful.

Channel Setting

Select the channel to transmit, and configure the weekday and time period.

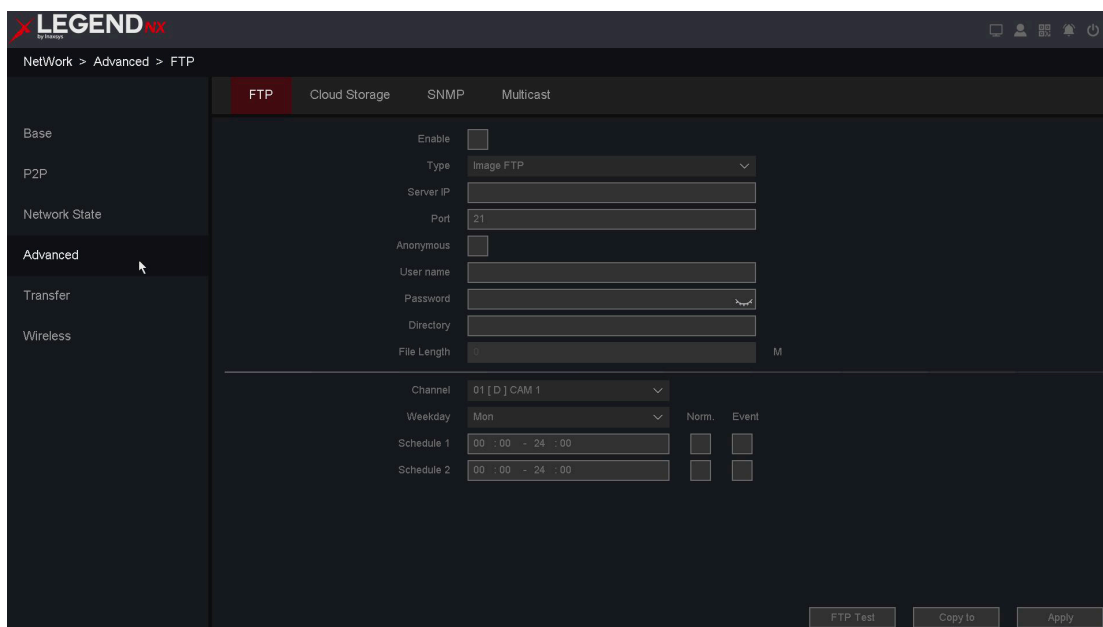

Figure 9-9 FTP

Note

- After completing the configuration, click **FTP Test** to verify that the FTP service is available. Use **Copy To** to copy the current channel configuration to other channels. Click **Apply** to activate the configuration.
- Some FTP servers require a special authorization code as the password. Please refer to your FTP service provider for details.

Cloud Storage

As a new feature, the device supports uploading video and images to cloud storage. This allows recorded data stored on the hard drive to be uploaded to services such as Google Drive or Dropbox. Pricing depends on the respective cloud service provider's subscription plan. must be installed within the DVR/UVR for Cloud Storage to function. Once configured correctly, the system will automatically upload video and images to the cloud.

Before You Start

Ensure that you have registered accounts for Google Drive and Dropbox.

Steps:

1. Go to **Main Menu** → **Network** → **Advanced** → **Cloud Storage**.

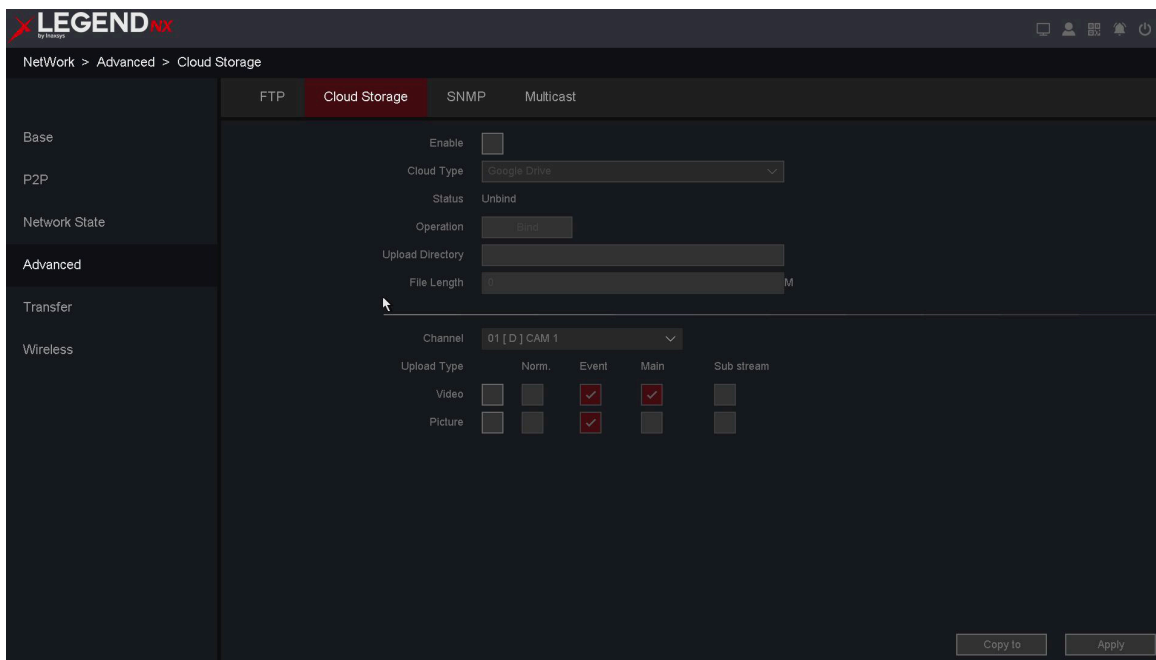

Figure 9-10 Cloud Storage

Cloud Type

Supports two cloud storage types: **Google Drive** and **Dropbox**.

Upload Directory

Set the directory path of your cloud account for file storage.

File Length

Set the duration of video files to be uploaded to the cloud.

Channel

Select the channel for file upload. Different channels can be configured with different upload plans.

Upload Type

Includes four types: **Norm**, **Event**, **Main**, and **Sub Stream**.

Video

- In **Norm** mode, the device continuously uploads video files while recording is in progress.
- In **Event** mode, the device uploads video files according to the configured alarm trigger plan.
- **Main** and **Sub Stream** allow you to select which recording stream type to upload.

Picture

Same as video configuration. Supports **Norm** and **Event** upload types.

2. Enable **Enable**.
3. Select the cloud type.
4. Click **Bind**.
5. A window will appear displaying a verification code and a QR code for scanning.

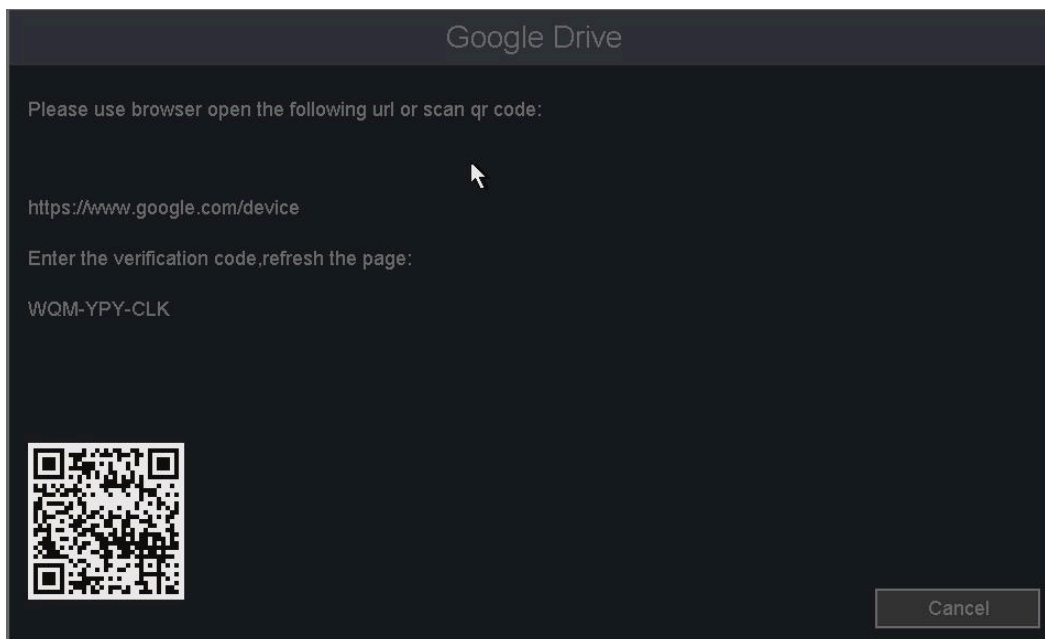

Figure 9-11 Google Drive

6. Use your mobile phone to scan the QR code, or use your computer to open the URL displayed in the prompt.
7. Follow the on-screen instructions to enter the verification code, sign in to your account, and click **Allow**.

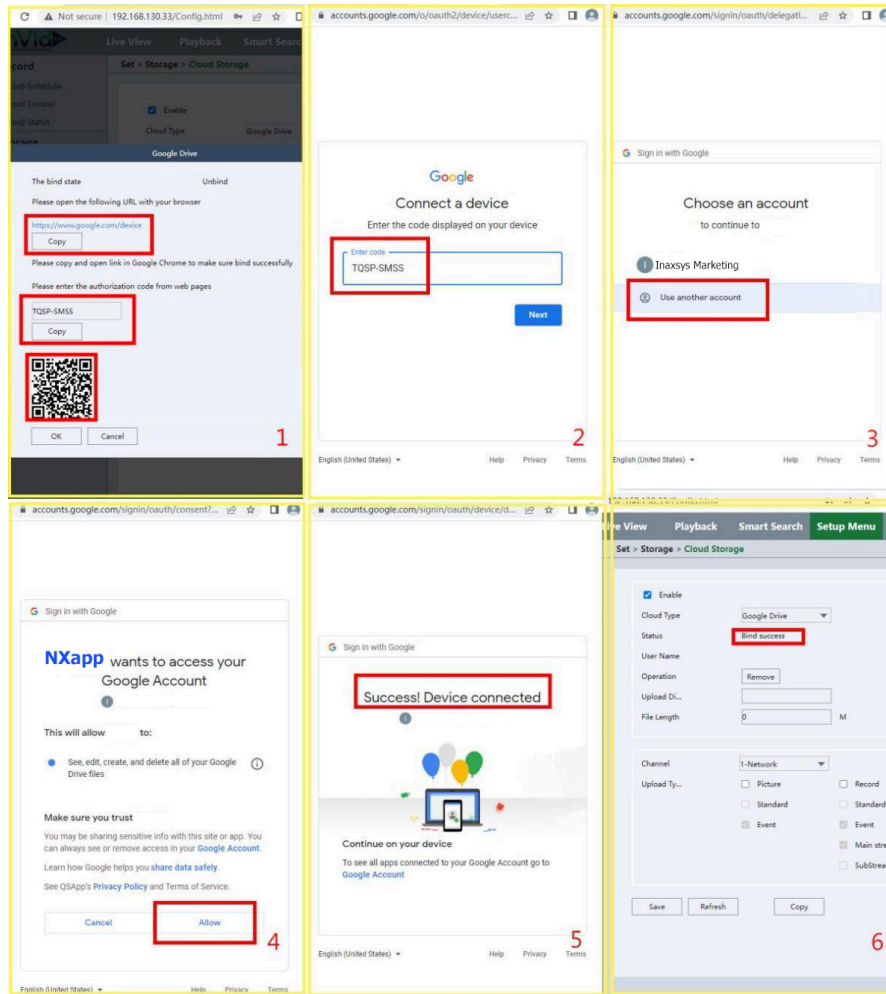

Figure 9-12 Mobile Operation Example

8. After completing the authorization and clicking **Allow** for your Google Drive or Dropbox account, a **Bind Success** message will be displayed. You can then click **Logout** to close the window.
9. The **Status** field will display “Bind Your Login Name”.
10. In **Upload Directory**, enter a folder name of your choice. This path will automatically be created in your Google Drive or Dropbox directory.
11. Click **Apply**.

SNMP

SNMP (Simple Network Management Protocol) is an Internet-standard protocol used to collect and organize information about managed devices on IP networks and to modify that information to change device behavior.

Steps:

1. Go to **Main Menu** → **Network** → **Advanced** → **SNMP**.
2. There are three SNMP versions.

FTP Cloud Storage **SNMP** Multicast

V1/V2 **V3**

SNMP version V1 V2

Read community public

Write community private

Trap address 127 . 0 . 0 . 1

Trap port 162

Trap community name public

Default Apply

Figure 9-13 V1/V2 Version

FTP Cloud Storage **SNMP** Multicast

V1/V2 **V3**

SNMP version V3

Read security name public

Security level no auth, no priv

Authentication algorithm MD5

Authentication password

Private-key algorithm DES

Private-key password

Write security name private

Security level no auth, no priv

Authentication algorithm MD5

Authentication password

Private-key algorithm DES

Private-key password

Default Apply

Figure 9-14 V3 Version

3. Select the protocol as required.
4. Click **Apply** to save.

Multicast

In computer networking, multicast (one-to-many or many-to-many distribution) is a group communication method where information is sent to a group of destination computers simultaneously.

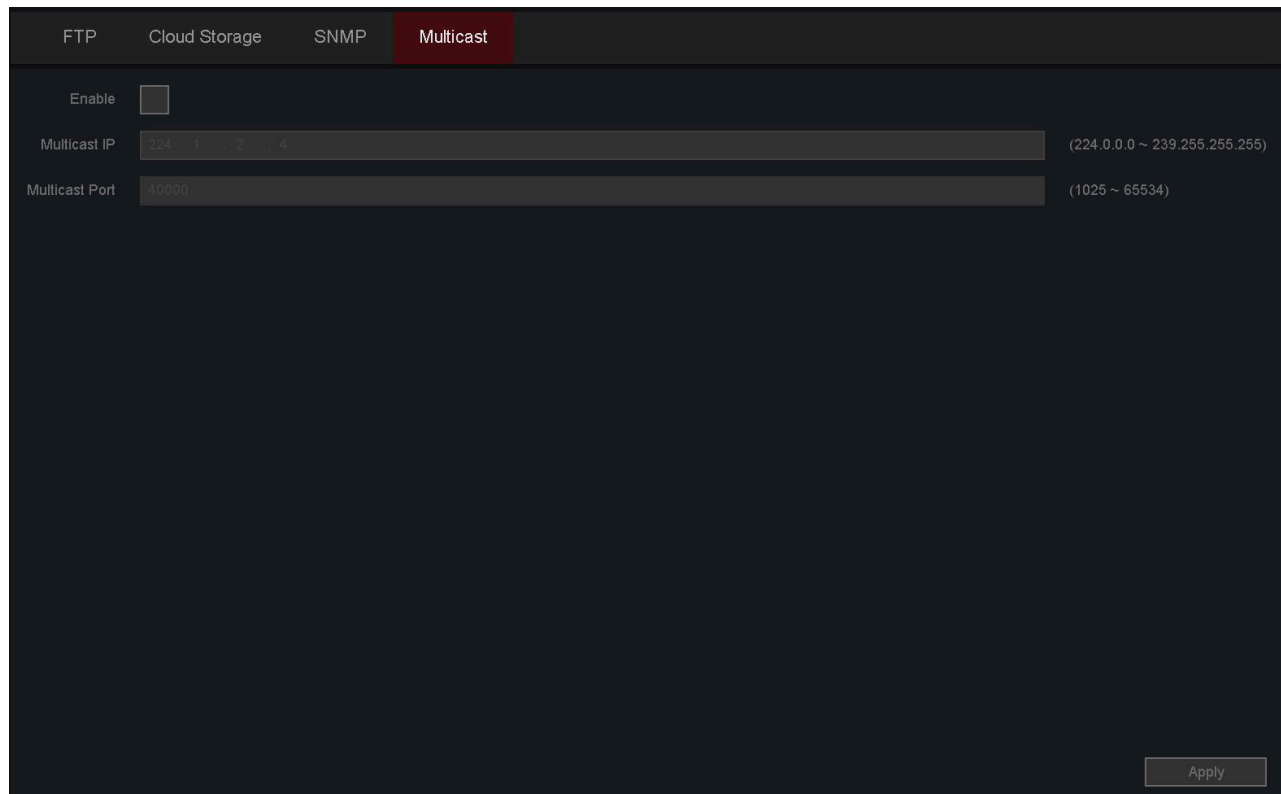

The screenshot shows a web interface for configuring Multicast. At the top, there are tabs for FTP, Cloud Storage, SNMP, and Multicast. The Multicast tab is active. Below the tabs, there is an 'Enable' checkbox which is currently unchecked. Underneath, there are two input fields: 'Multicast IP' with the value '224.1.1.2' and a range '(224.0.0.0 ~ 239.255.255.255)', and 'Multicast Port' with the value '40000' and a range '(1025 ~ 65534)'. An 'Apply' button is located in the bottom right corner.

Figure 9-15 V3 Multicast

9.2.4 Transfer

UPNP

UPNP is a networking standard that uses Internet protocols to allow network-connected electronic devices to automatically detect and identify each other.

Before You Start

If you want to use the UPNP function, enable the UPNP™ function on your router. When the device network working mode is multi-address, the default device route must be on the same network segment as the LAN IP address of the router.

Steps:

1. Go to **Main Menu** → **Network** → **Transfer** → **UPNP**.

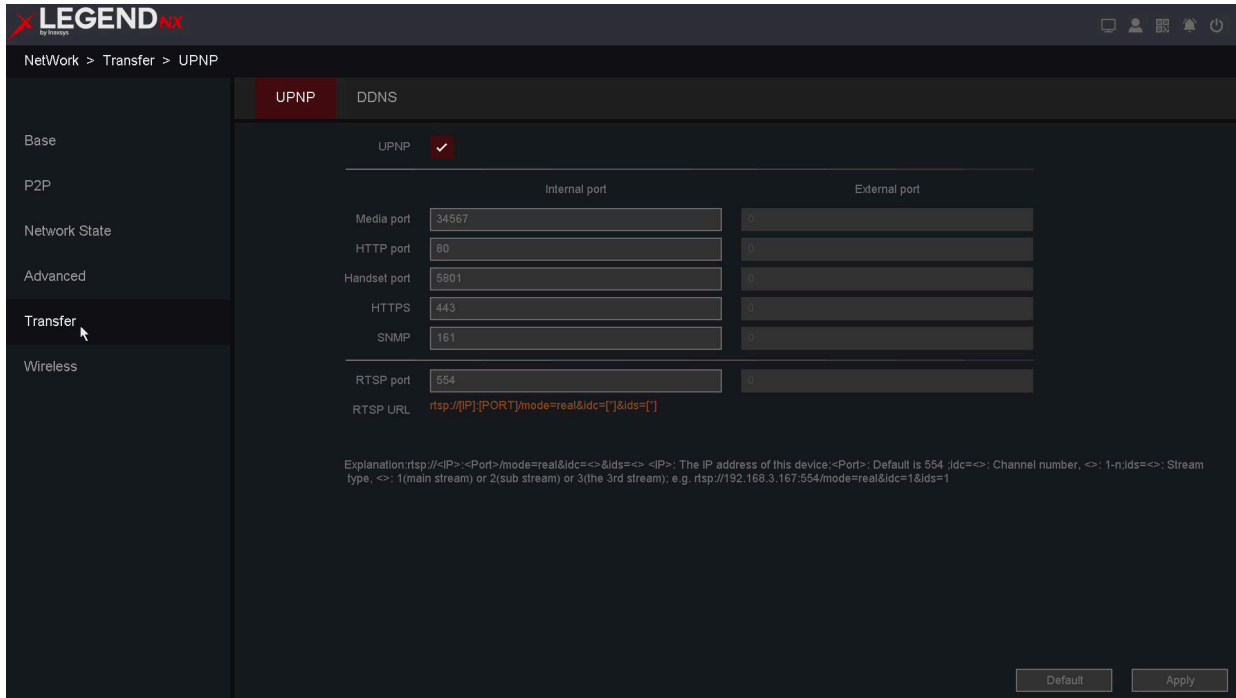

Figure 9-16 UPNP

2. Turn on **UPNP**.
3. Configure the **Media Port**, **HTTP Port**, **Handset Port**, **HTTPS**, and **SNMP** as required. (If you are not sure, do not modify them, as they may conflict with other system ports.)

Note

- **RTSP Port:** RTSP (Real Time Streaming Protocol) is a network control protocol used in entertainment and communication systems to control streaming media servers. Enter the RTSP port in the corresponding field. The default RTSP port is **554**, and it can be modified as needed.
- The RTSP port value should be **554** or within the range **1024–65535**. Other ports should be within the range **1–65535**, and each port must be unique. If multiple devices use UPNP™ under the same router, each device must use a different port number.

4. Click **Apply**.

DDNS

DDNS is a service that automatically updates DNS records when client PCs obtain IP settings from a DHCP server. When DDNS is enabled on the UVR, you can access the device using a domain name provided by your Internet Service Provider (ISP).

Before You Start

Register for Oray DDNS, CN99 DDNS, DynDNS, or NO-IP services with your ISP.

Steps:

1. Go to **Main Menu** → **Network** → **Advanced** → **DDNS**.

2. Turn on **Enable**.
3. Select a DDNS type.
4. Enter the required parameters, including **Domain Name**, **User Name**, and **Password**.

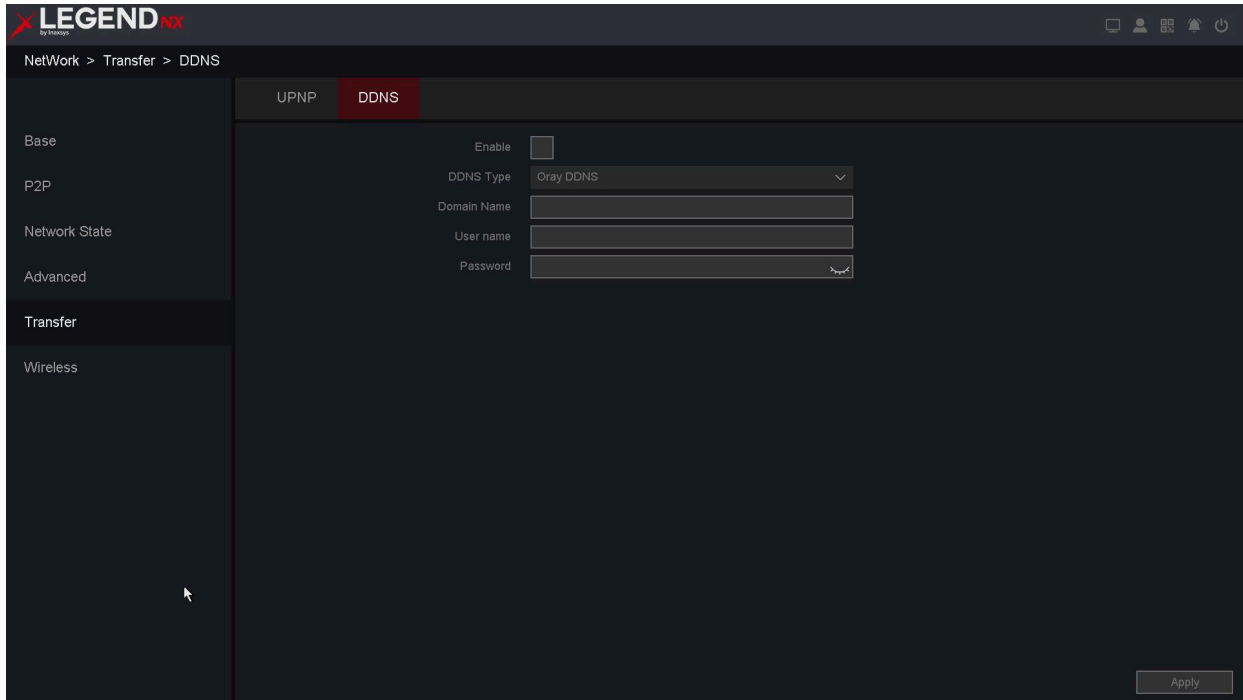

Figure 9-17 DDNS

DDNS Type

Select the DDNS service provider, including Oray DDNS, CN99 DDNS, DynDNS, and NO-IP. This option can be configured according to user requirements.

Domain Name

Enter the domain name provided by your ISP.

User Name/Password

Enter the username and password corresponding to the domain name.

5. Click **Apply**.

9.2.5 Wireless

3G/4G

Before You Start

Insert the 3G/4G module into the UVR before configuration.

Steps:

1. Go to **Main Menu** → **Network** → **Wireless** → **3G/4G**.
2. Turn on **Enable**.

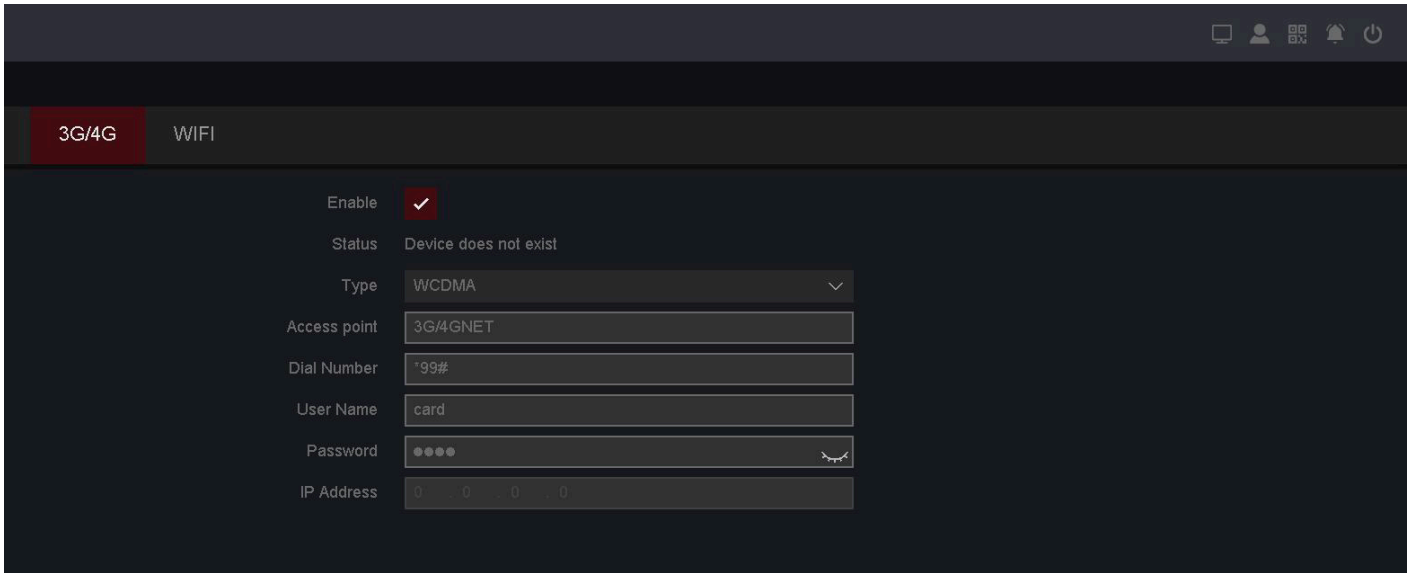

Figure 9-18 3G/4G

3. Configure the parameters as required.
4. Click **Apply**.

WIFI

After successful configuration, the UVR can connect to the LAN via a wireless network.

Before You Start

Insert the WiFi module into the NVR before configuration.

Steps:

1. Go to **Main Menu** → **Network** → **Wireless** → **WIFI**.
2. Click **Search**.

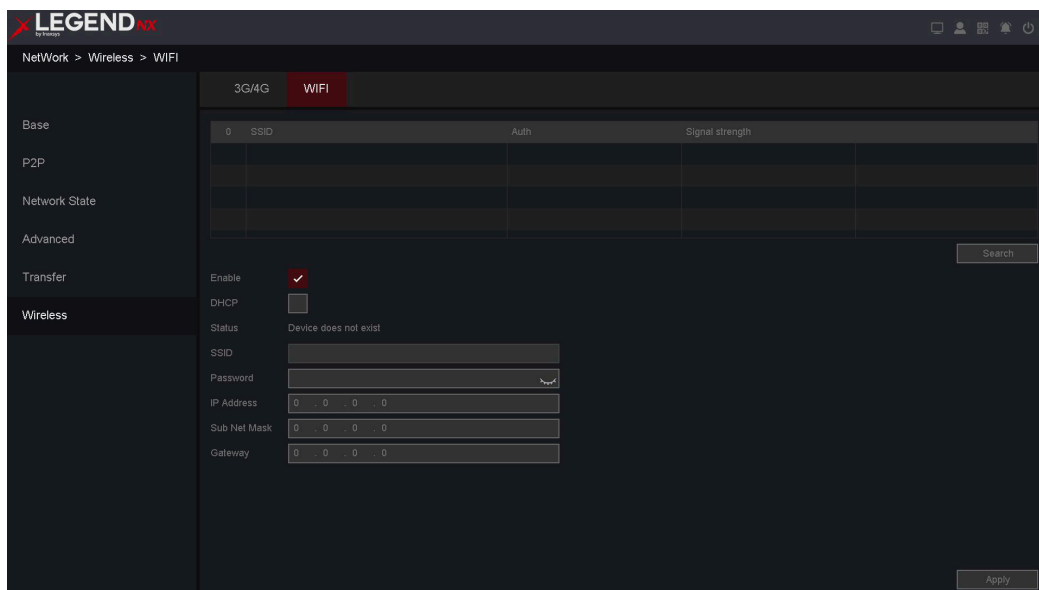

Figure 9-19 WIFI

3. Turn on **Enable**.
4. Turn on **DHCP**.
5. Enter the wireless **Password**.
6. Click **Apply**.
7. After a successful connection, the **Status** will change to **Connected**.
8. Optional: Go to **Main Menu** → **Channel** → **IP Channel** to add a camera. For details, refer to **7.1.1 IP Channel**.

Note

The local network segment and the WiFi network segment must not be the same. You can go to **Main Menu** → **Network** → **LAN** to verify the IP address of the local network.

9.3 Camera

9.3.1 Channel

Channel Type

Please refer to **2.5 Adding Online IP Cameras** for details.

Channel Set

Please refer to **6.3.1 Network Camera** for details.

Encode

By configuring the encoding parameters, you can define settings that affect image quality, such as **Compression Type**, **Resolution**, **Frame Rate**, **Bit Rate Type**, and **Quality**.

The UVR supports dual-stream encoding. You can configure both the main stream and sub-stream encoding on this screen.

Before You Start

Ensure that an IPC device is already added and its connection status is **Connected**.

Steps:

1. Go to **Main Menu** → **IP Channel** → **Encode**.
2. Alternatively, go to **Main Menu** → **Channel** → **IP Channel** → **Channel Set** → **Encode**.

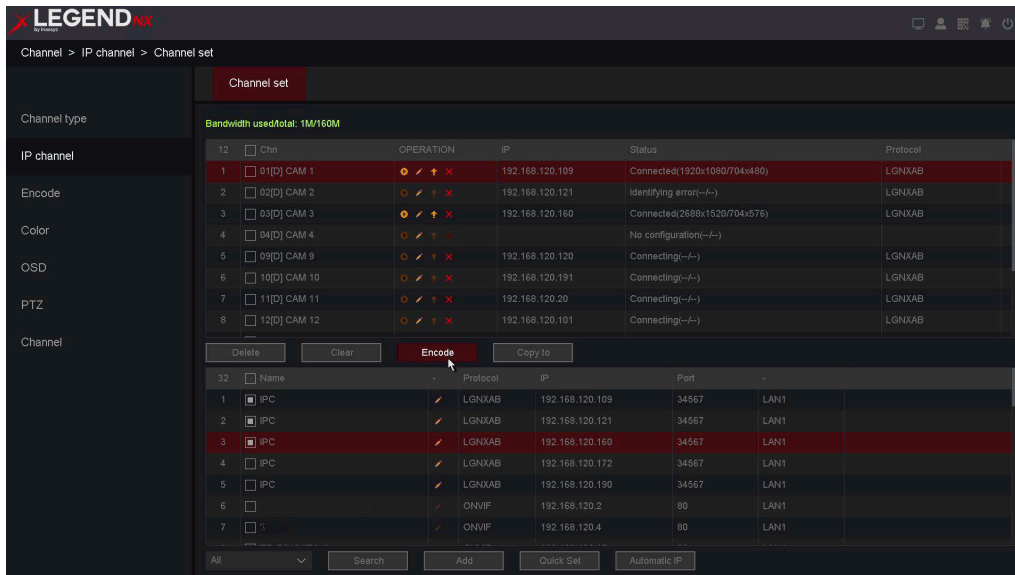

Figure 9-20 Channel

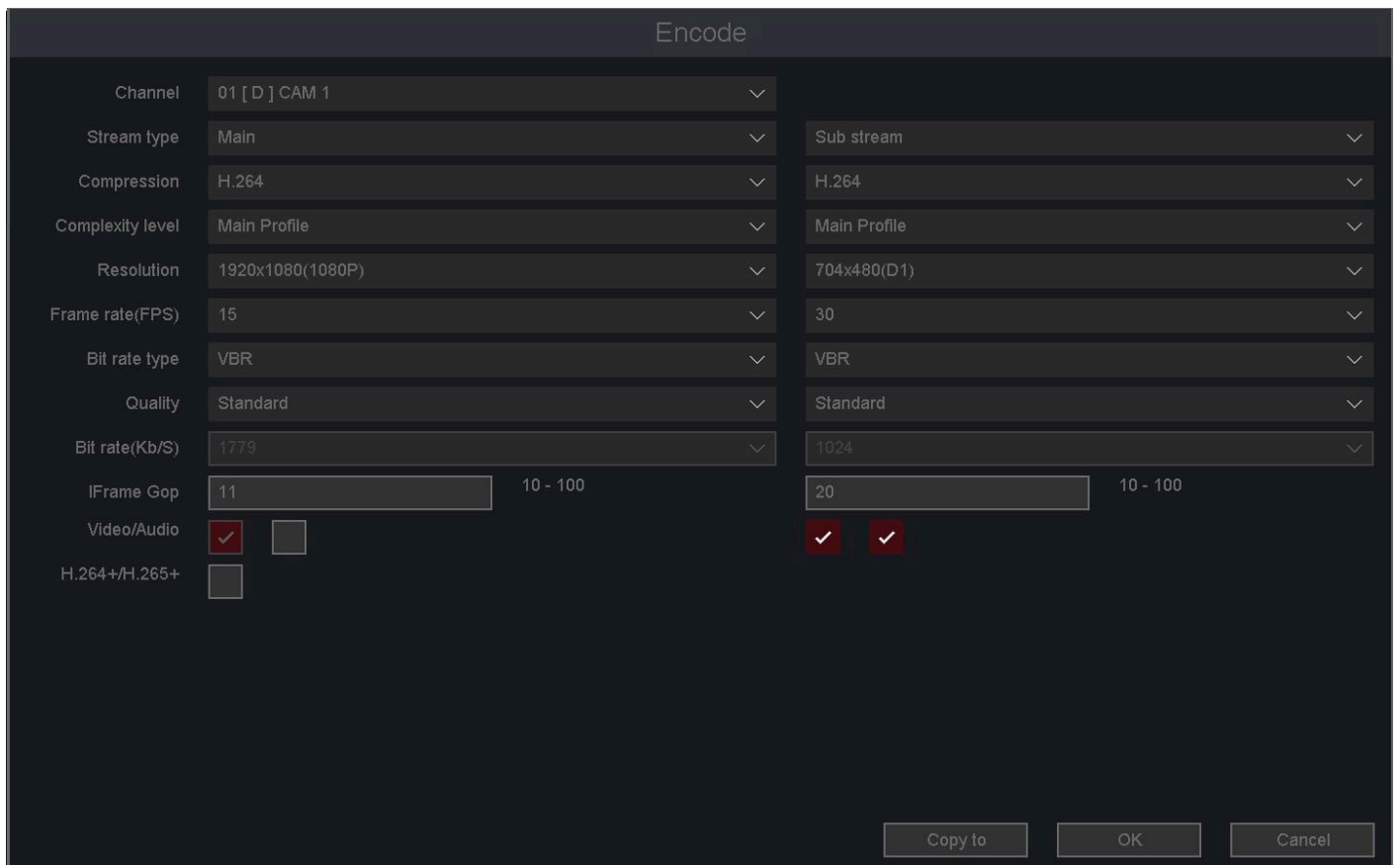

Figure 9-21 Encode config

3. Configure the parameters as required.

Channel

Select the channel to configure.

Stream Type

Main Stream / Sub Stream / Event Stream / Mobile Stream.

Compression

H.265 is the encoding compression protocol. It also supports H.264 IP cameras.

Complexity Level

Base Profile / Main Profile / High Profile.

Resolution

Defines the resolution of the encoded video.

Frame Rate (FPS)

Specifies the number of frames per second in the encoded video.

Bit Rate Type

CBR / VBR.

Quality

Lowest / Low / Standard / Good / Better / Best.

Bit Rate (Kb/s)

Defines the bandwidth value.

Stream Range

Specifies the bitrate range for this channel.

I-frame

I-frame interval setting, ranging from 10 to 100.

Video/Audio

Enable encoding of video and audio in recorded files. Video in the main stream is always enabled.

H.264+/H.265+

Enables smart encoding technology, which can reduce HDD storage usage by up to 80%–90% in static scenes.

- Optional: You can use the **Copy to** function to quickly apply the same parameters to all channels.

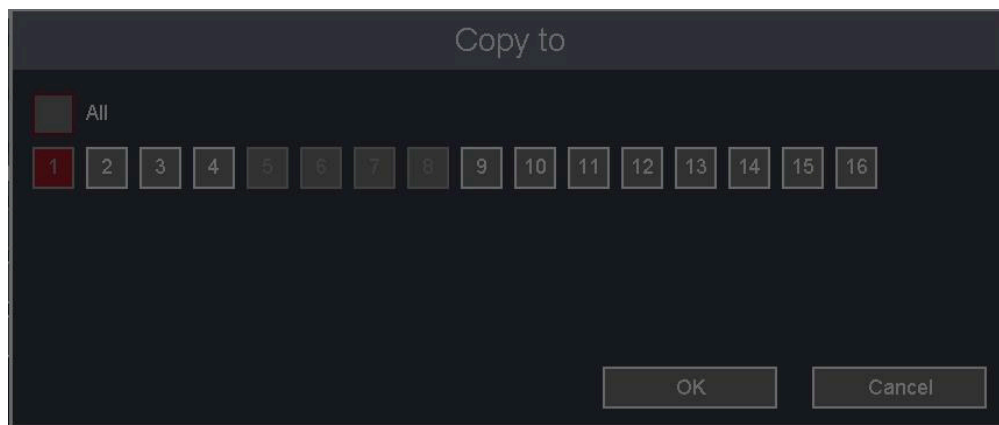

Figure 9-22 Copy to

Note

If you want to use the **Copy to** function, it is recommended to use it with cameras of the same model.

5. Click **OK**.

PTZ

This section describes how to configure the actions that the PTZ camera will perform when a corresponding alarm is triggered.

Before You Start

Ensure that presets, patrols, and patterns are supported by the PTZ protocols.

Steps:

1. Go to **Main Menu** → **Channel** → **PTZ**.

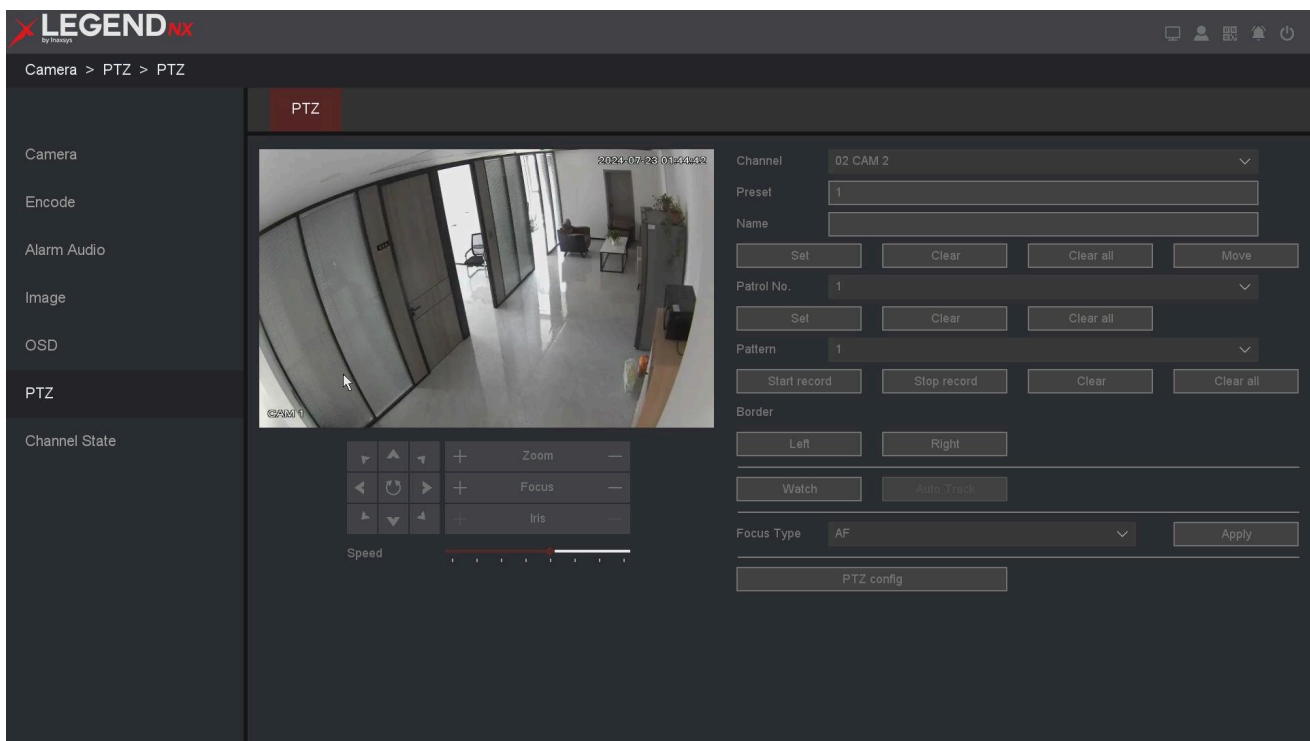

Figure 9-23 PTZ

2. Select the channel to configure.
3. Configure the parameters as required.

Channel

Select the channel to configure.

Preset

This feature allows the camera to move to a specified position (for example, a window) when an event occurs. Up to 255 preset points can be configured.

Name

The name of the preset point will be displayed in the upper-left corner of the screen after it is called.

Patrol No.

Patrols allow the PTZ camera to move between different key points and remain at each position for a defined duration before proceeding to the next point. These key points correspond to presets. You can configure up to four cruise routes. Each cruise route includes preset points, the dwell time at each preset, and the cruising speed.

0	Preset	Speed	Stay time(s)
---	--------	-------	--------------

Figure 9-24 Cruise set

Pattern

Patterns can be configured by recording the movement of the PTZ camera. You can call a pattern to make the PTZ follow the predefined path.

Border

Defines linear boundaries, including left and right limits.

Watch



Figure 9-25 Watch

Waiting time(s)

The waiting time, in seconds, after the watchdog function is enabled. The value can be set between 5 and 720 seconds.

Watch mode

Multiple scanning modes are available, including Auto Pan, Patrol Scan, Pattern Scan, Preset, and Area Scan.

Watch mode No.

The number corresponding to the selected scan mode.

Auto Track

Enables automatic tracking of moving objects. When dynamic objects are detected, the camera will follow them automatically.





Focus Type

Autofocus function adapted for IPC.

PTZ Config

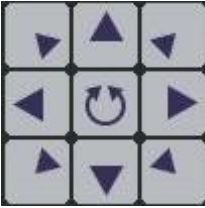
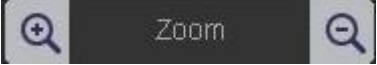
Control of the PTZ head is mainly performed through the RS485 port.

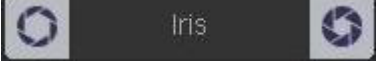
Table 9-1 PTZ Config

Items	Function Description
	Direction control and automatic cycling
	Zoom+, Zoom-
	Focus+, Focus-
	Iris+, Iris-
	Adjusts the speed of PTZ movement

9.3.2 Encode

Encode

Please refer to **10.3.1 Channel** for details.

9.3.3 Image Parameters

Image

The camera is preconfigured with default settings before leaving the factory, which are suitable for standard applications. If higher performance is required, the camera supports image adjustments such as Brightness, Contrast, Saturation, Hue, and Sharpness. Some high-end cameras also support advanced settings such as Image Adjustment, Exposure, Backlight, White Balance, and Day/Night settings. In this section, you can configure the camera to improve image quality and achieve a better viewing experience.

Before You Start

Ensure that an IPC device is already connected and its status is **Connected**.

Steps:

1. Go to **Main Menu** → **Channel** → **Color**.

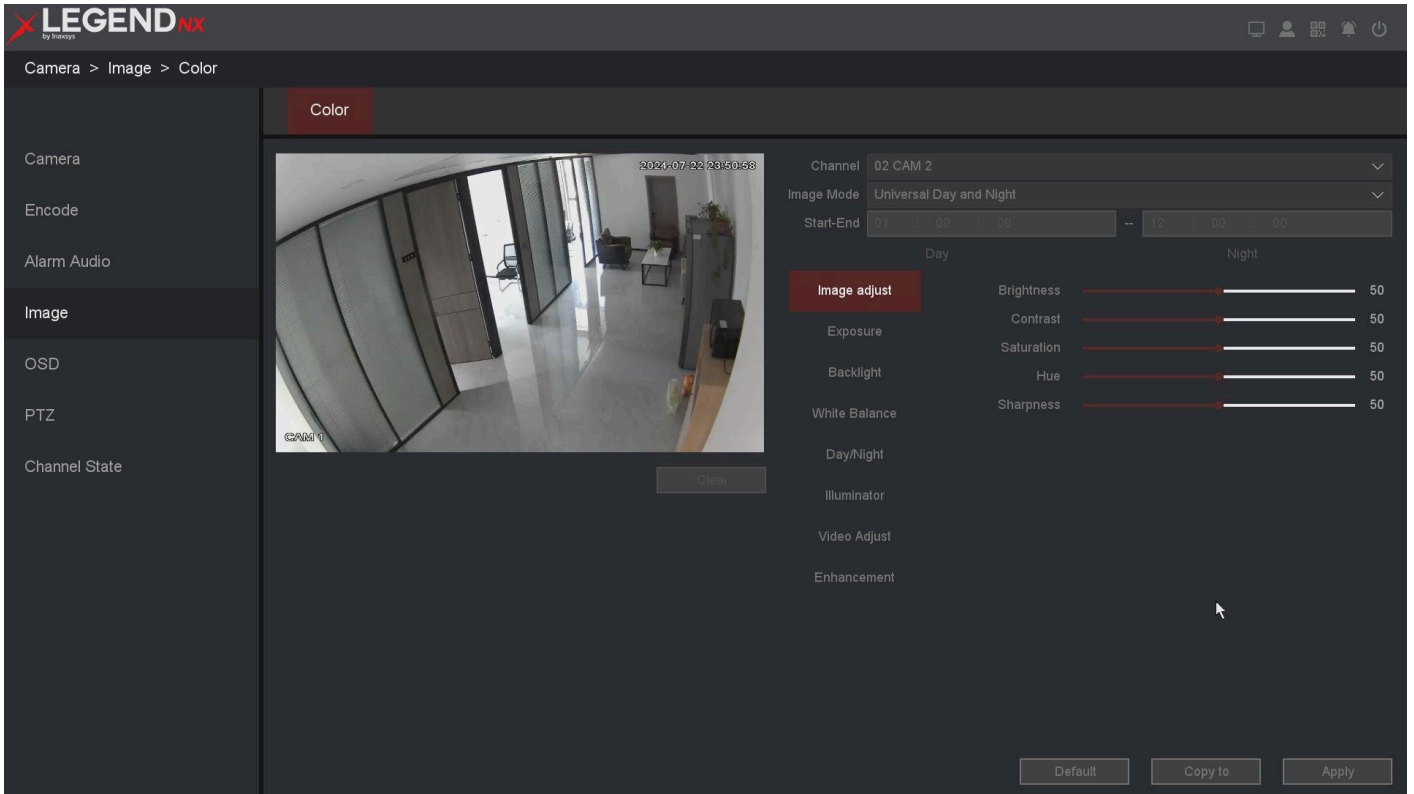

Figure 9-26 Image

2. Configure the parameters as required.

Channel

Select the channel to configure.

Image Mode

Defines the image mode for a specified period. Available options are **Auto** and **Scheduled**.

- **Auto mode** applies the same image settings continuously (24 hours).
- **Scheduled mode** allows two separate configurations (Day period and Night period). You can define different image settings for each period.

Start-End

When the image mode is set to **Manual**, specify the start time and end time for the Day or Night period.

3. Configure the camera parameters on this screen if the camera is compatible with the UVR.

Table 9-2 Set IP Camera Parameters

Functions	Description	Functions	Description
-----------	-------------	-----------	-------------

Image adjust	Brightness: 0–100 Contrast: 0–100 Saturation: 0–100 Hue: 0–100 Sharpness: 0–100	Day/Night	Auto / Color On / Color Off Switch Type: IR synchronous filter Time: 0–120 seconds Smart IR: Manual / Close / Auto
Exposure	Auto: Automatically sets exposure time Manual: Set exposure time manually by specifying an exact value	Video adjust	Image: Close / Up / Down / Left / Right / Center Rotate: Off / 90 / 180 / 270
Backlight	DWDR: Close / DWDR / WDR (if supported by IPC) Limit: Adjust the DWDR or WDR level Backlight Compensation: When DWDR is disabled, BLC options are Off / HLC / BLC	Enhancement	NR Level: 0–6 Defog: Close / Auto / Manual Smart Light: Close / Manual / Auto
White balance	Auto: Automatically adjusts white balance Manual: Adjust white balance by setting Red Gain and Blue Gain values		

Image adjust

Customize image parameters, including brightness, contrast, and saturation, to optimize both live view and recording quality.

Exposure

Set the camera exposure time (from 1/10000 to 1/3 second). A higher exposure value produces a brighter image.

Backlight

Adjust the camera's wide dynamic range (0–100). When there is a significant difference in brightness between the subject and the background, configure the WDR value accordingly.

White Balance

When a color cast occurs, compensate by adjusting the corresponding complementary color.

Day/Night

Configure the camera to operate in **Day**, **Night**, or **Auto** mode based on ambient lighting conditions.

Video Adjust

Adjust the orientation and angle of the image.

Enhancement

Optimize image contrast and overall visual quality.

OSD

Configure the OSD (On-Screen Display) settings for the camera, including Channel Name, Date/Time format, Record Status, Alarm Status, and more. For additional details, refer to **6.3.1 Network Camera - OSD**.

Before You Start

Ensure that an IPC device is already connected and its status is **Connected**.

Steps:

1. Go to **Main Menu** → **Channel** → **OSD**.
2. Select a camera.

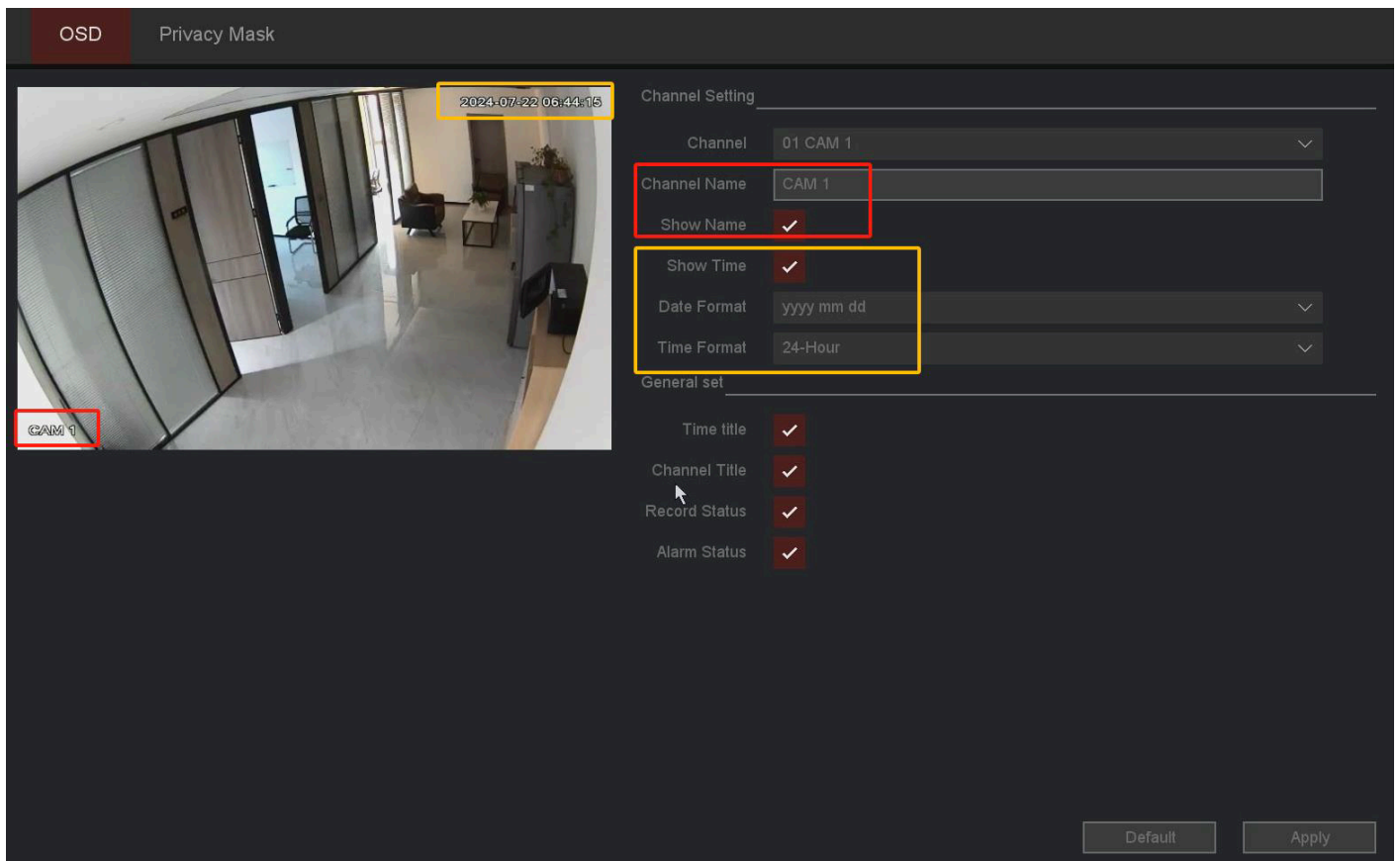

Figure 9-27 OSD

3. Configure the parameters as required.
4. You can choose whether to display the channel name and time, and customize them as needed.
5. Click **Apply**.

The settings are divided into two parts: **Channel Settings** and **General Settings**. Channel settings are used to configure IPC and analog channels, while general settings control the local display of the UVR.

For Channel Settings:

Channel

Select the channel to configure.

Channel Name

Specify the name of the channel.

Show Name, Show Time

Enable or disable the display of the channel name and time on the screen.

Date Format, Time Format

Set the display format for date and time.

For General Settings:

Channel Title

Enable or disable the display of the channel title on the monitor screen.

Record Status, Alarm Status

Enable or disable the display of recording status and alarm status on the screen.

Cover

The Cover function allows you to mask sensitive areas in the monitoring view. It supports masking up to four areas simultaneously.

Before You Start

Confirm the areas that need to be masked in advance.

Steps:

1. Go to **Main Menu** → **Channel** → **OSD** → **Cover**.

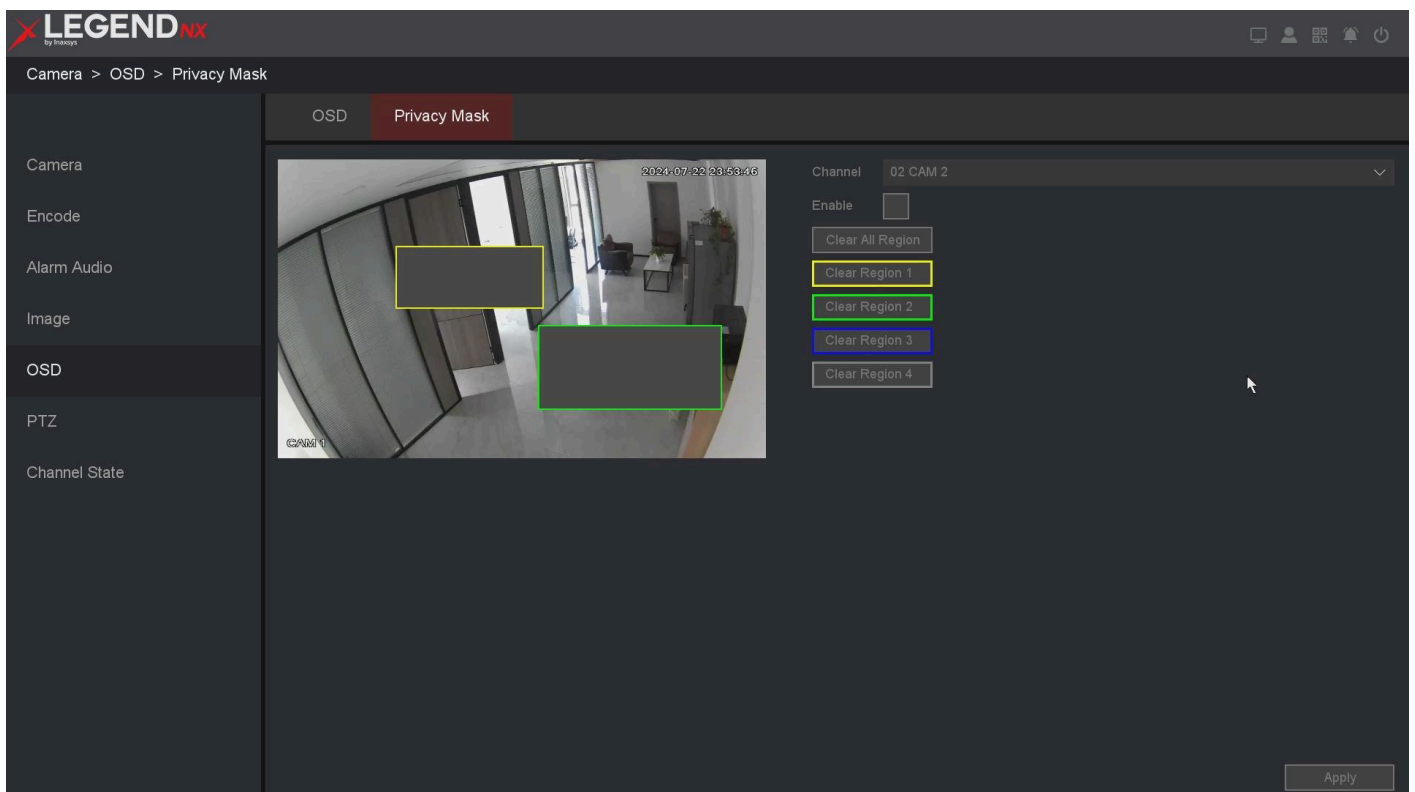

Figure 9-28 Privacy Mask

2. Select the camera for which you want to define the masking area.
3. In the preview window, select two opposite corners to draw a rectangular masking area (Region 1).
4. Repeat the same operation to draw Regions 2 to 4.
5. Enable **Enable**.
6. Click **Apply**.

Note

Up to four privacy mask areas can be configured. The size of each area can be adjusted.

9.4 Normal Event

9.4.1 Motion Detection

Motion Detection

Motion detection allows the video recorder to detect moving objects within the monitored area and trigger alarms. Please refer to **6.3.2 Event**.

9.4.2 Video Lost

Detects video signal loss from a camera and triggers corresponding alarm actions.

Before You Start

Ensure that your IPC supports this function.

Steps:

1. Go to **Main Menu** → **Event** → **Detect** → **Loss**.

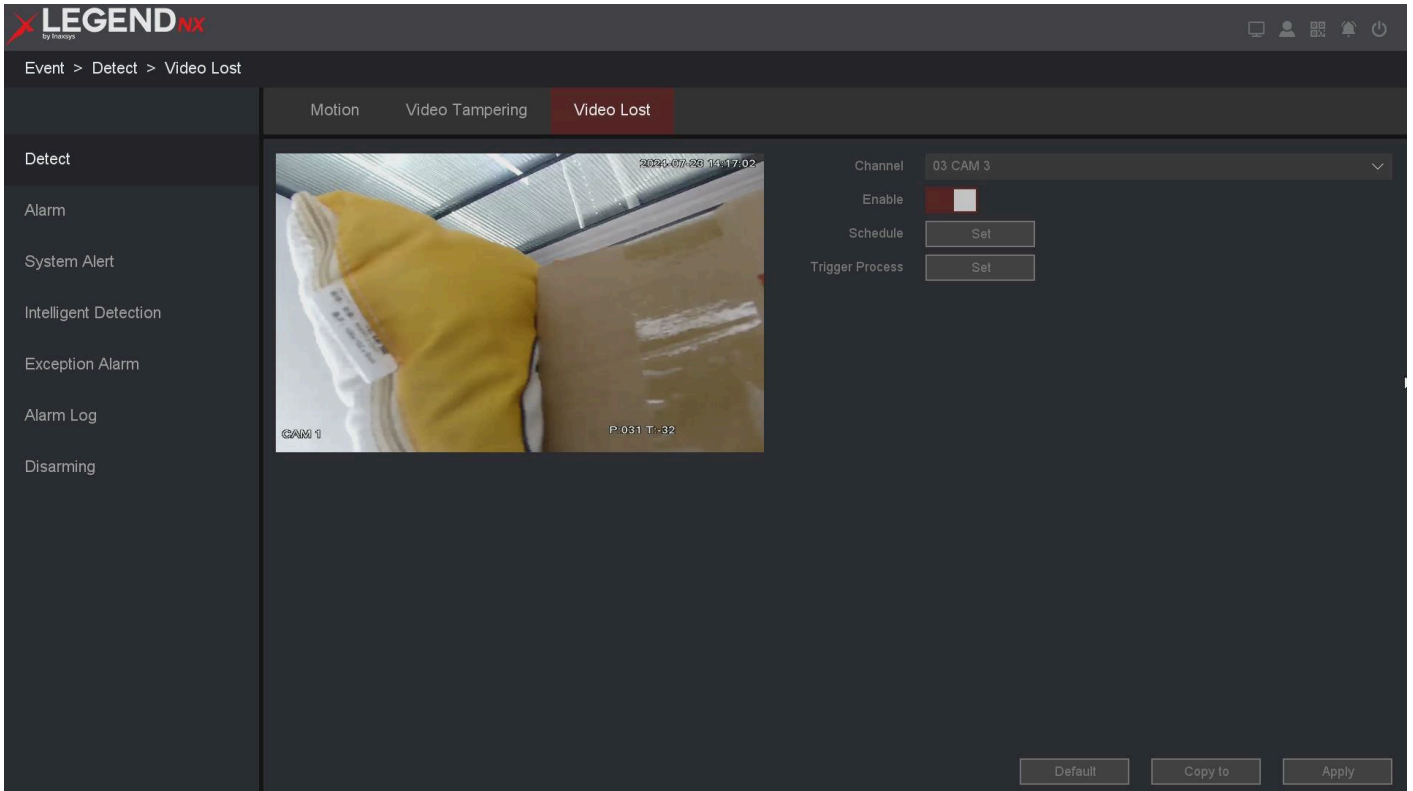

Figure 9-29 Video Lost

2. Set **Channel**.
3. Enable **Enable**.
4. Configure the arming **Schedule**. Refer to **6.4.2 Configure Arming Schedule** for details.
5. Configure the **Trigger Process**. Refer to **6.3.3 Configure Alarm Trigger Process** for details.
6. Click **Apply**.

9.4.3 Exception

Exception settings define how the system handles various abnormal conditions, including **No Writable Disk**, **Disk Error**, **Disk Full**, **Network Disconnect**, **IP Conflict**, and **S.M.A.R.T.**

No Writable Disk

This exception is triggered when all HDDs are set to read-only. The system can notify the user through **Show Message**, **Buzzer**, **Send Email**, and **Alarm Output**.

Disk Error

This exception is triggered when an HDD write error occurs or when the HDD is not formatted. The system can notify the user through **Show Message** and **Buzzer**.

Disk Full

You can define a minimum remaining disk space threshold. When reached, the system triggers actions such as **Show Message**, **Buzzer**, **Send Email**, and **Alarm Output**.

Network Disconnect

This exception is triggered when the network connection is lost. The system can notify the user through **Show Message**, **Buzzer**, and **Alarm Output**.

IP Conflict

This exception occurs when the device IP conflicts with another device on the same network. The system can notify the user through **Show Message**, **Buzzer**, and **Alarm Output**.

S.M.A.R.T.

This exception relates to HDD health monitoring. It is triggered when the HDD status is abnormal or operating conditions are degraded. The system can notify the user through **Show Message** and **Buzzer**.

Steps:

1. Go to **Main Menu** → **Event** → **Exception**.

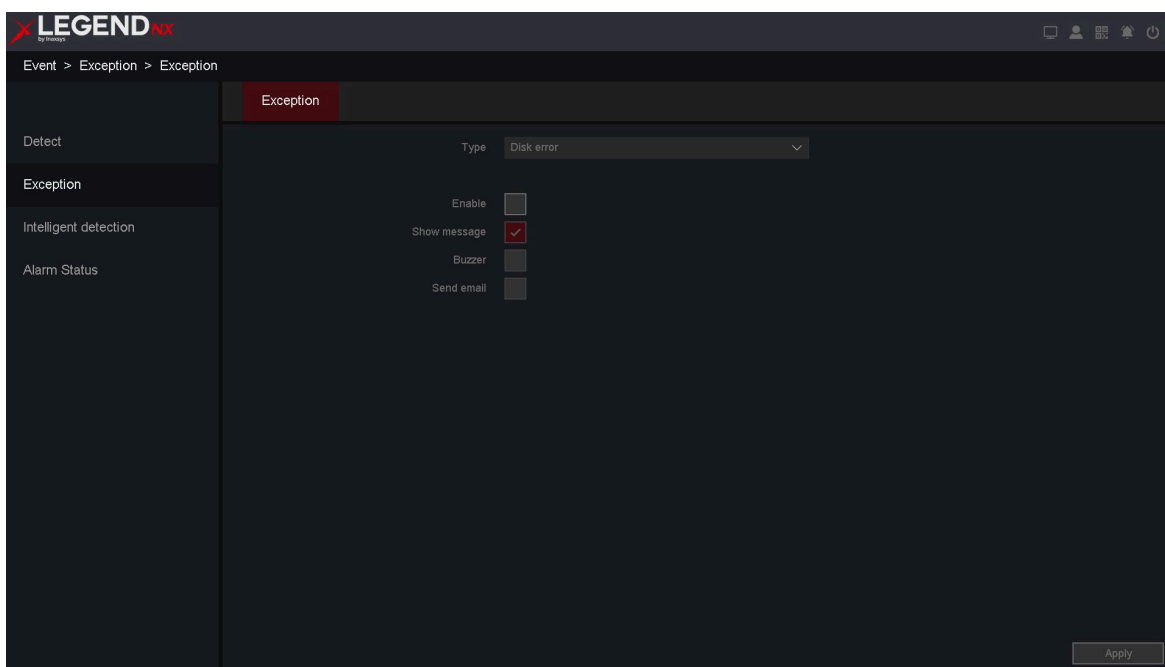

Figure 9-30 Alert

2. Select **Type**.
3. Turn on **Enable**.
4. Configure the other parameters as required. When the configured events occur, notifications will be displayed in **Alarm Status**.
5. Click **Apply**.

9.5 Smart Event

Line Crossing & Area Intrusion

Line Crossing & Area Intrusion allow you to filter alarms by enabling **Target Detection** such as **Human Shape Filter** or **Vehicle Shape Filter**, so that alarms not triggered by humans or vehicles are ignored.

These functions are categorized as **Perimeter Protection (PP)**. Only certain camera models support these features. Please refer to **6.3.2 Event** for details.

9.6 Storage

9.6.1 Schedule

Schedule

Go to **Main Menu** → **Storage** → **Schedule** → **Schedule**.

This is the recording schedule. Please refer to **6.4.2 Configure Recording Schedule** for details.

9.6.2 HDD Management

If you are using the HDD for the first time, initialize it after installation. Please refer to **6.4.1 Storage**.

Storage Mode

Multiple HDDs can be managed in groups. Video from specified channels can be recorded to a designated HDD group through HDD settings. You can also switch the storage mode of the hard disk, including **Group**, **Quota (Capacity)**, and **Quota (Time)**.

Before You Start

Install at least one HDD in the video recorder.

Steps:

1. Go to **Main Menu** → **Storage** → **Storage Mode**.
2. Select **Mode** as **Group**.
3. Select a group number.
4. Select the channels to record on the HDD group.

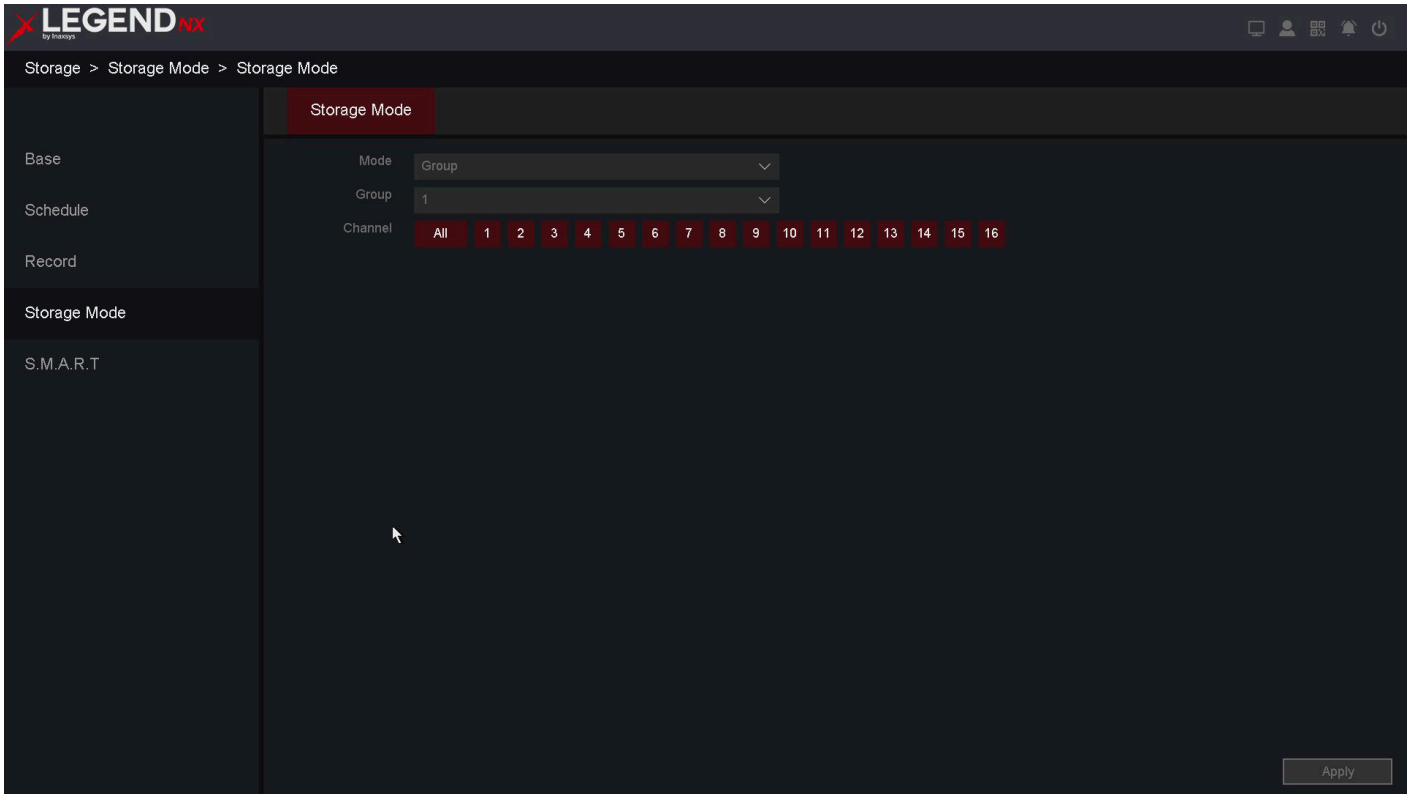

Figure 9-31 Group

5. Click **Apply**.
6. Restart the video recorder to activate the new storage mode settings.
7. After restarting, go to **Main Menu** → **Storage** → **Base**.
8. Click **Edit** for the desired HDD to assign the group.
9. Select a group number for the current HDD.

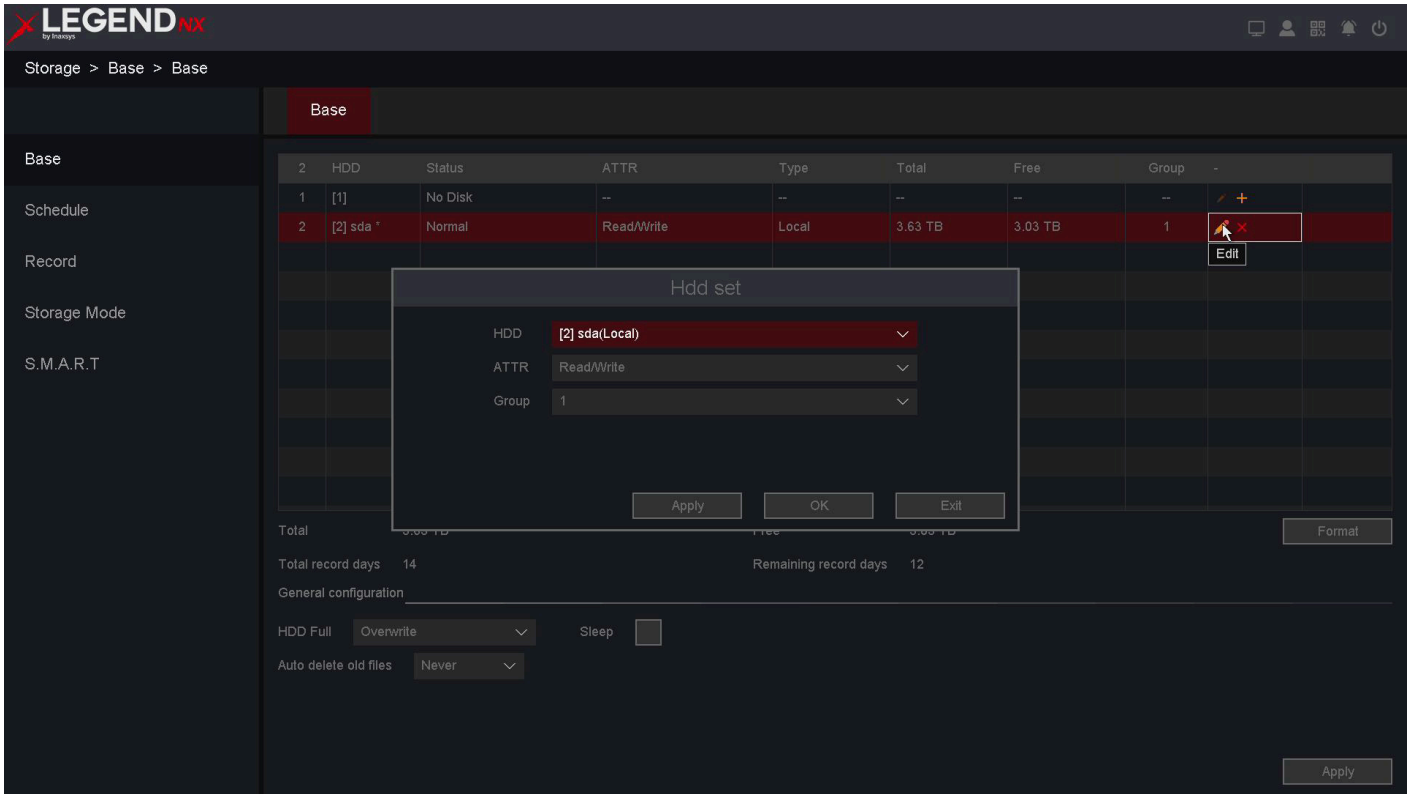

Figure 9-32 HDD Set

10. Click **OK**.

Note

You can configure up to 16 groups in **Group** mode, and each channel operates independently within its assigned group. If a channel does not belong to any group, no video will be saved. If a channel belongs to multiple groups, it will use the storage space of these groups sequentially until all groups are full.

Configure HDD Quota (Capacity)

Each camera can be assigned a storage quota (capacity) for saving video files.

Steps:

1. Go to **Main Menu** → **Storage** → **Storage Mode**.
2. Select **Mode** as **Quota (Capacity)**.
3. Select a camera in **Channel** to configure its quota.
4. Enter the recording capacity in **Record quota (GB)** and **Picture quota (GB)**.

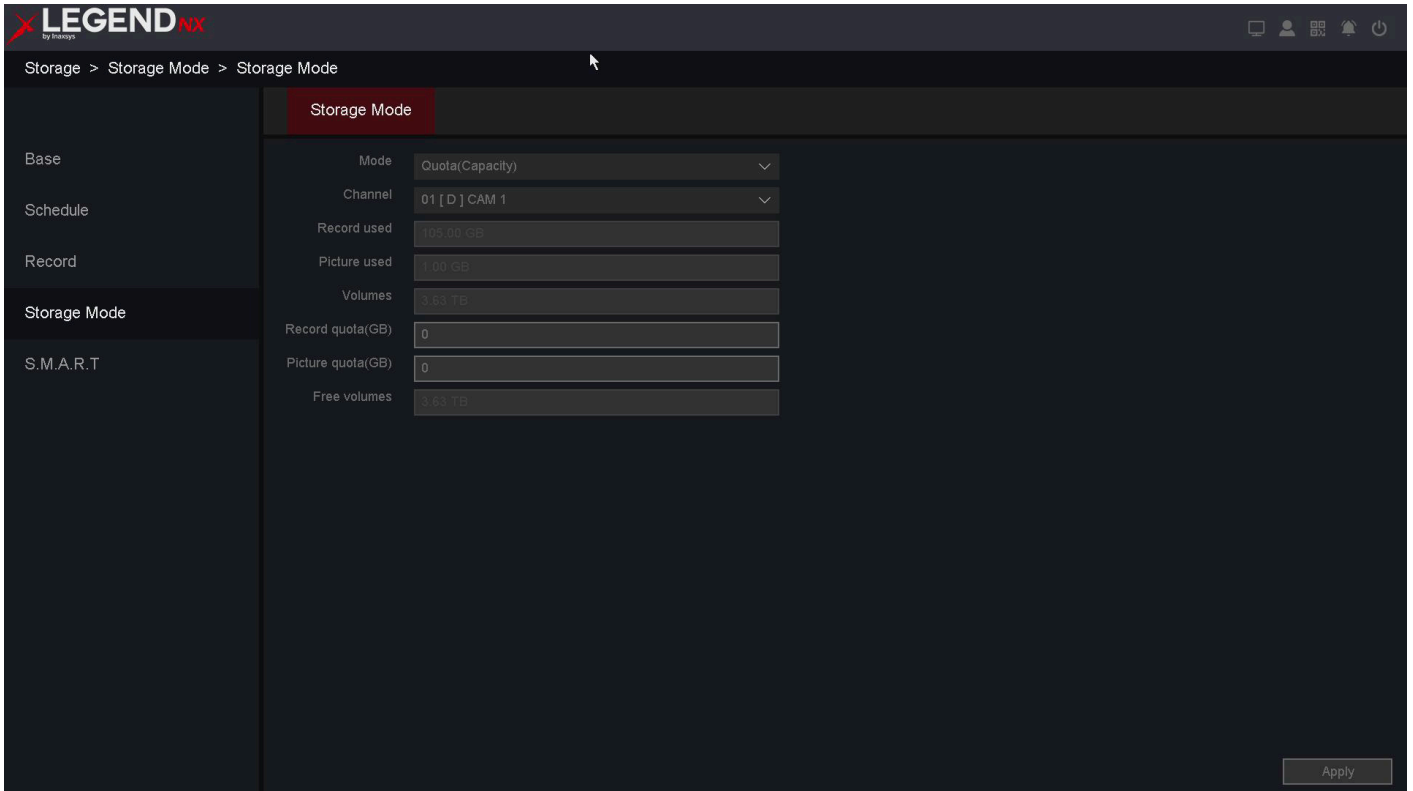

Figure 9-33 Quota

5. Click **Apply**.
6. Click **OK** on the video recorder to activate the new settings.

Note

When the quota capacity is set to 0, all cameras will share the total HDD capacity for both video and images. Each time you change the storage mode, you must restart the UVR device.

Record used

Displays, in real time, the storage space used by video files for the selected channel.

Picture used

Displays, in real time, the storage space used by image files for the selected channel.

Volumes

Total capacity of all hard drives.

Record Quota

Allows you to manually set the storage quota for video files of the channel.

Picture quota

Allows you to manually set the storage quota for image files of the channel.

Free volumes

Displays the remaining available space after subtracting the space allocated to other channels.

Note

Regarding the capacity quota mechanism (it must be configured to allow overwriting when the hard disk is full):

- Video recording has priority. If there is available HDD capacity, recording will continue. The system prioritizes storing as much video as possible.
- When the storage is full, the earliest recorded data that exceeds the quota will be overwritten first.
- Once the quota capacity is allocated, the system overwrites the earliest recorded data within the quota.

Configure HDD Quota (Time)

Each camera can be assigned a time-based quota for storing video files.

Steps:

1. Go to **Main Menu** → **Storage** → **HDD Manage** → **Mode Settings**.
2. Select **Mode** as **Quota (Time)**.
3. Select a camera in **Channel** to configure its quota.
4. Enter the number of days in **Record Quota (Day)**.

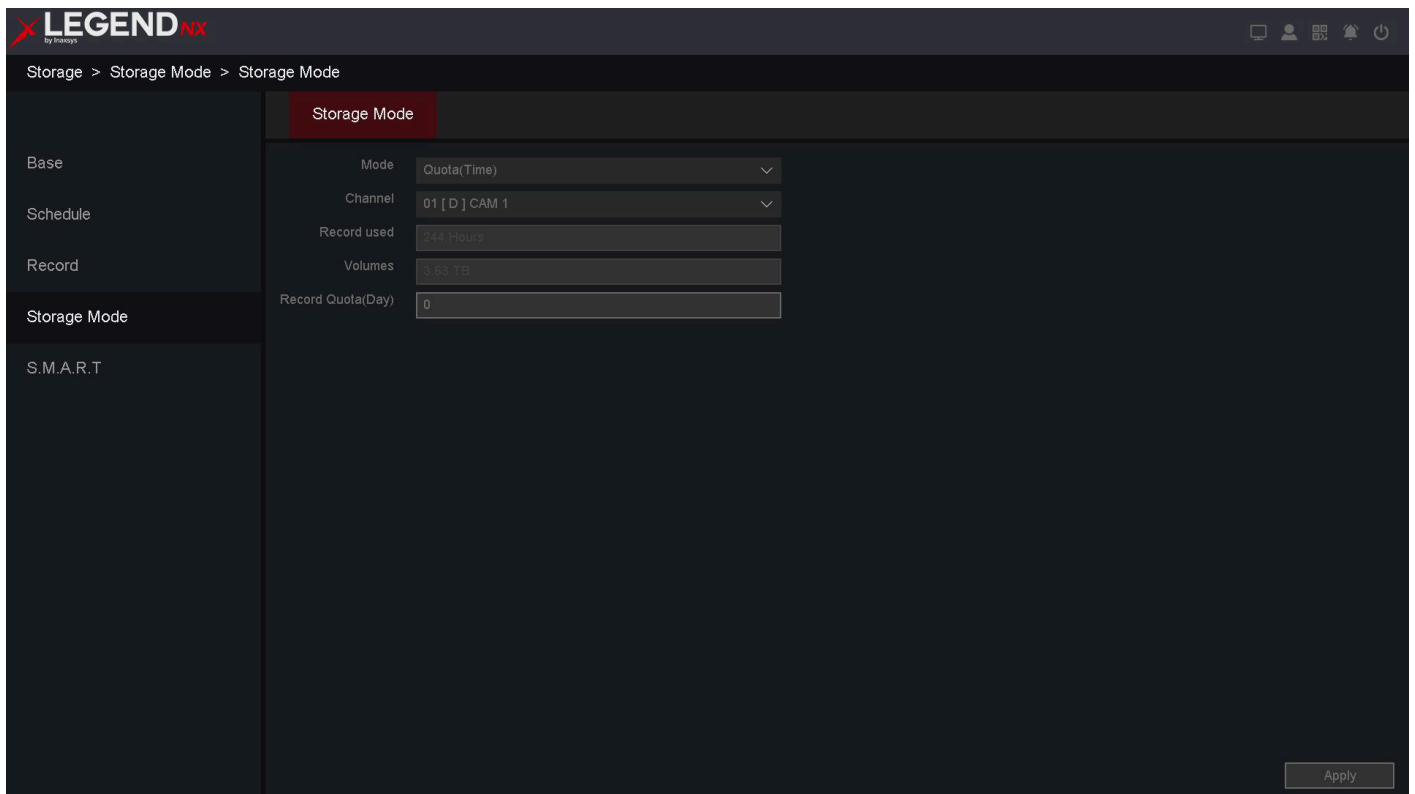

Figure 9-34 Quota

5. Click **Apply**.
6. Click **OK** on the video recorder to activate the new settings.

Note

When **Record Quota (Day)** is set to 0, all cameras will share the total HDD capacity for both video and images. Each time you change the storage mode, you must restart the UVR device.

Record used

Displays, in real time, the storage space used by video files for the selected channel.

Volumes

Total capacity of all hard drives.

Record Quota (Day)

Set the retention time for a channel from 0 to 60 days. During this period, newly recorded video files will not overwrite existing files.

Note

Regarding the time-based quota mechanism (it must be configured to allow overwriting when the hard disk is full):

- Video recording has priority. If there is available HDD capacity, recording will continue. The system prioritizes storing as much video as possible.
- When storage becomes full, the earliest recorded data that exceeds the configured time quota will be overwritten first.
- Until the block of the channel that exceeds the time quota is overwritten by recordings from other channels within their time quotas, the time quota mechanism for this channel will take effect.
- Because the video stream may vary dynamically, to ensure the time quota mechanism works effectively for this channel, you can set a larger time quota for other channels.

9.7 Backup

9.7.1 Backup

You can back up video recordings and export them to a backup device (such as a USB flash drive). Please refer to **Chapter 5 Backup**.

9.8 Playback

9.8.1 Normal Playback & Event Playback

Right-click and select **Playback** to enter the playback interface. You can also click the playback button below the preview screen to access the playback interface.

For **Normal Playback** and **Event Playback**, please refer to **4.2 Normal Playback** and **4.3 Event Playback**.

9.8.2 Label Play

Select **Label Play** to enter label playback mode.

Before You Start

Please ensure that you have added default labels during normal playback and that corresponding label records already exist in **File Management**, as shown below. You can also refer to **4.2 Normal Playback**.



Figure 9-35 Label Play

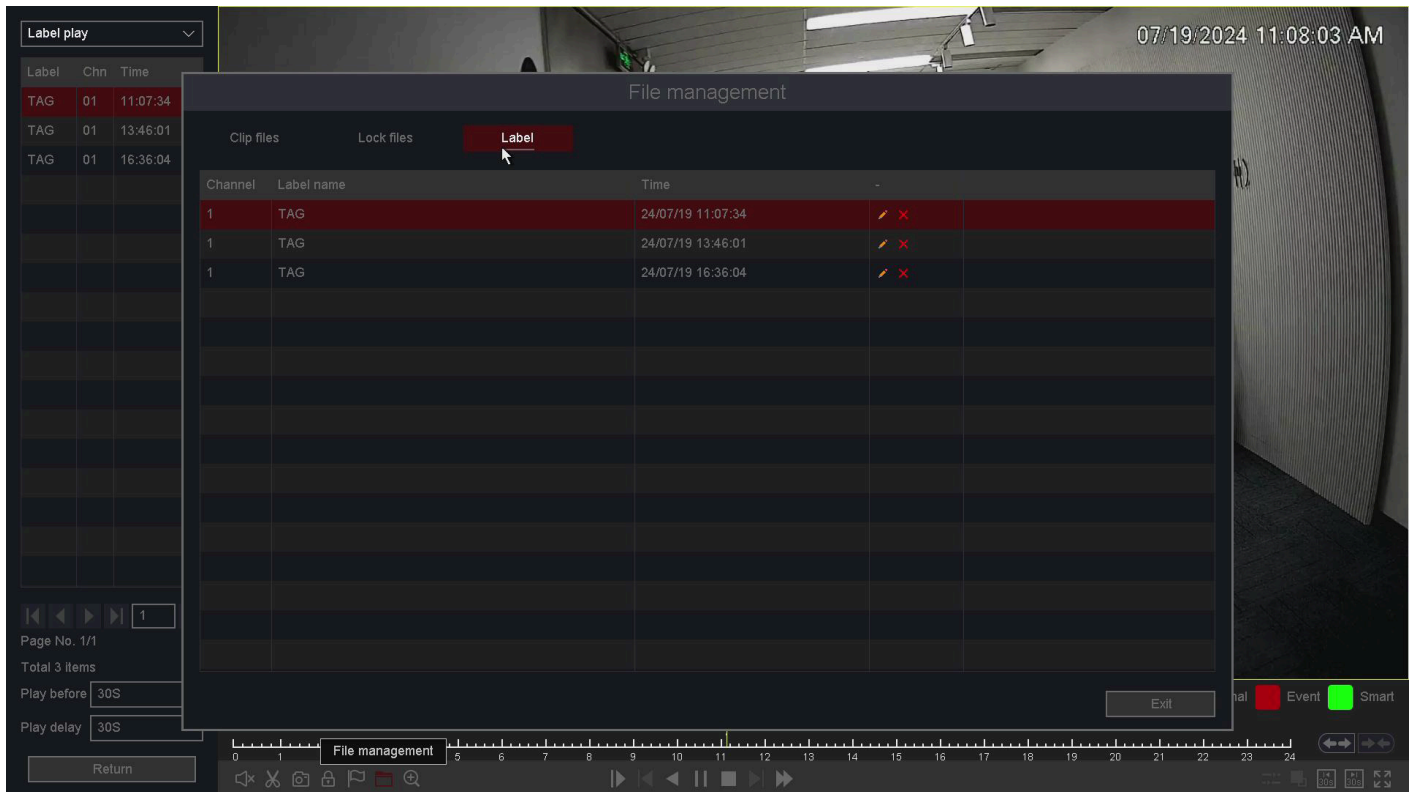

Figure 9-36 Backup and Retrieval

Steps:

1. Go to **Playback**.
2. Select **Label Play**.
3. Select the desired channels and set the time period.
4. Click **Search**.
5. The search results will be displayed as shown in the figure above.
6. Click a label in the list to start label playback as required.
7. Click the return button to go back to the previous interface and change the search channels.

Label

The name of the label, which can be edited in **File Management**.

Channel

The channel associated with the label.

Time

The time at which the label was created during playback.

The left and right arrows

Use these to switch pages and locate the desired label items.

Play before and Play delay

Set the playback duration before and after the labeled time.

Note

For the functions of these buttons, refer to **Table 4-2-1 Playback Interface Description**. The following functions are not available in label playback mode: **Sync/Async**, **Main/Sub stream**, and **Frame Control**.





9.8.3 Smart Play

Select **Smart Play** to enter Smart Playback mode.

Before You Start

Ensure that **Perimeter Protection** features such as Motion Detection, Line Crossing, or Area Intrusion are enabled on the device, and that alarm recordings have been generated.

Table 9-3 Description

Icon	Description	Icon	Description
	Draw a line on the video interface		Display motion detection in full screen
	Draw a quadrilateral area		Clear all drawn areas
	Draw a rectangular motion detection area		

Draw Line**Steps:**

1. Go to **Playback**.
2. Select **Smart Play**.
3. Select the channel and recording time as required.

4. Click **Play** or click the blue timeline.
5. Click the **Draw Line**  icon to draw a line on the video interface.
6. Click **Setting** to configure playback options such as **Skip Non-Focus Video**, and set the playback speed for **Non-Concerned Video** and **Attention Video**. You can also define the time before and after events (0 to 600 seconds), as shown below.

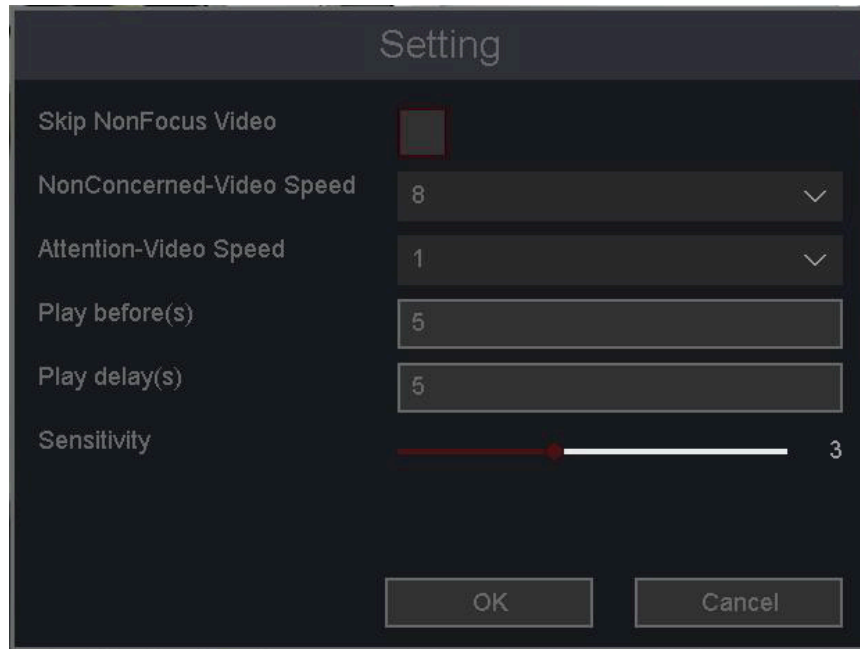

Figure 9-37 Draw Line

7. Click **Search**. The results will be displayed as shown below. Video segments with line-crossing events will be marked in **green**, and playback will follow the settings configured in step 6.

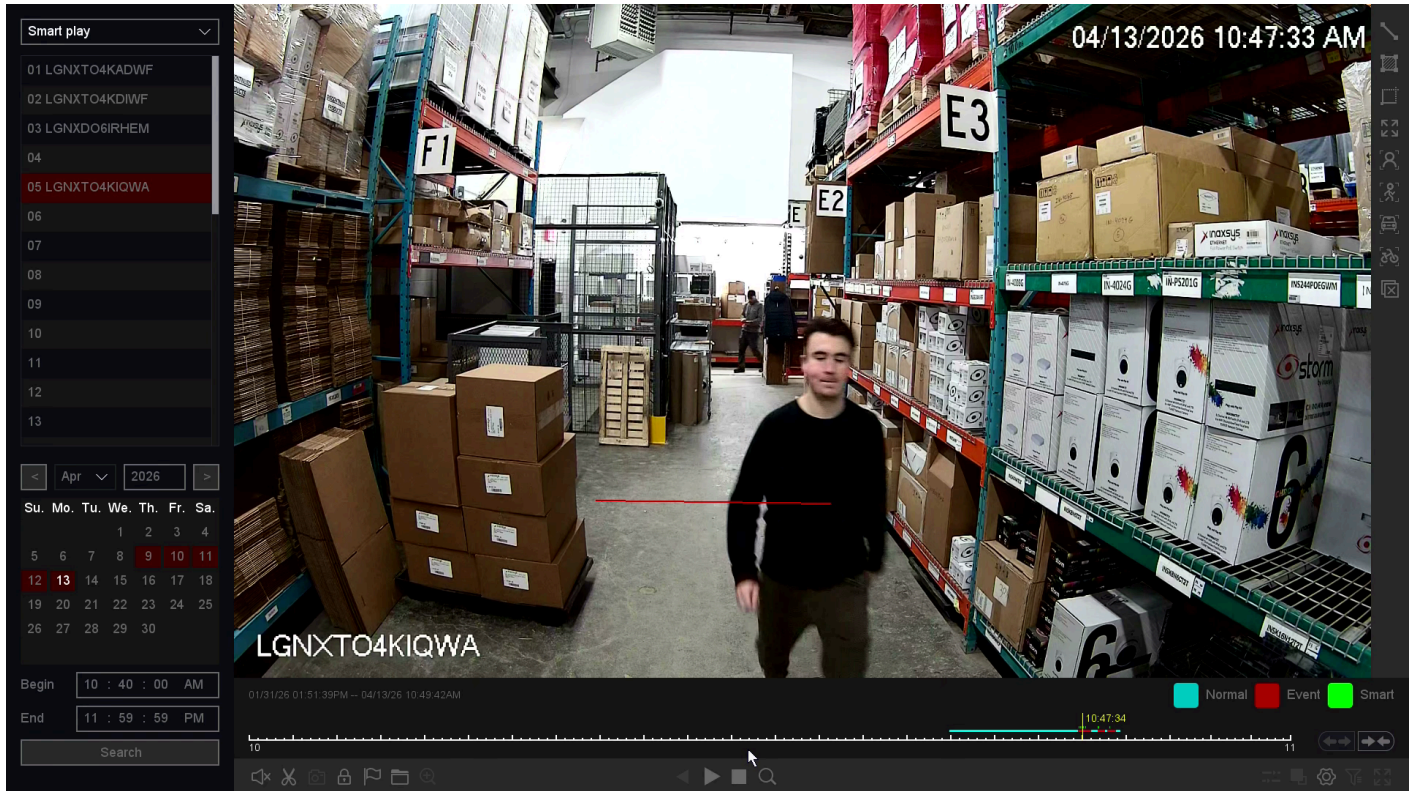



Figure 9-38 Search Results

Draw Quadrilateral

Steps:

1. Go to **Playback**.
2. Select **Smart Play**.
3. Select the channel and the record time as required.
4. Click **Play** or click the blue timeline.
5. Click the quadrilateral  icon to draw a quadrilateral on the video interface.
6. Click **Setting** to configure the parameters as required.
7. Click **Search**. The results will be displayed as shown below. Videos with Area Intrusion will be marked in **green**, and playback will follow the settings configured in Step 6.

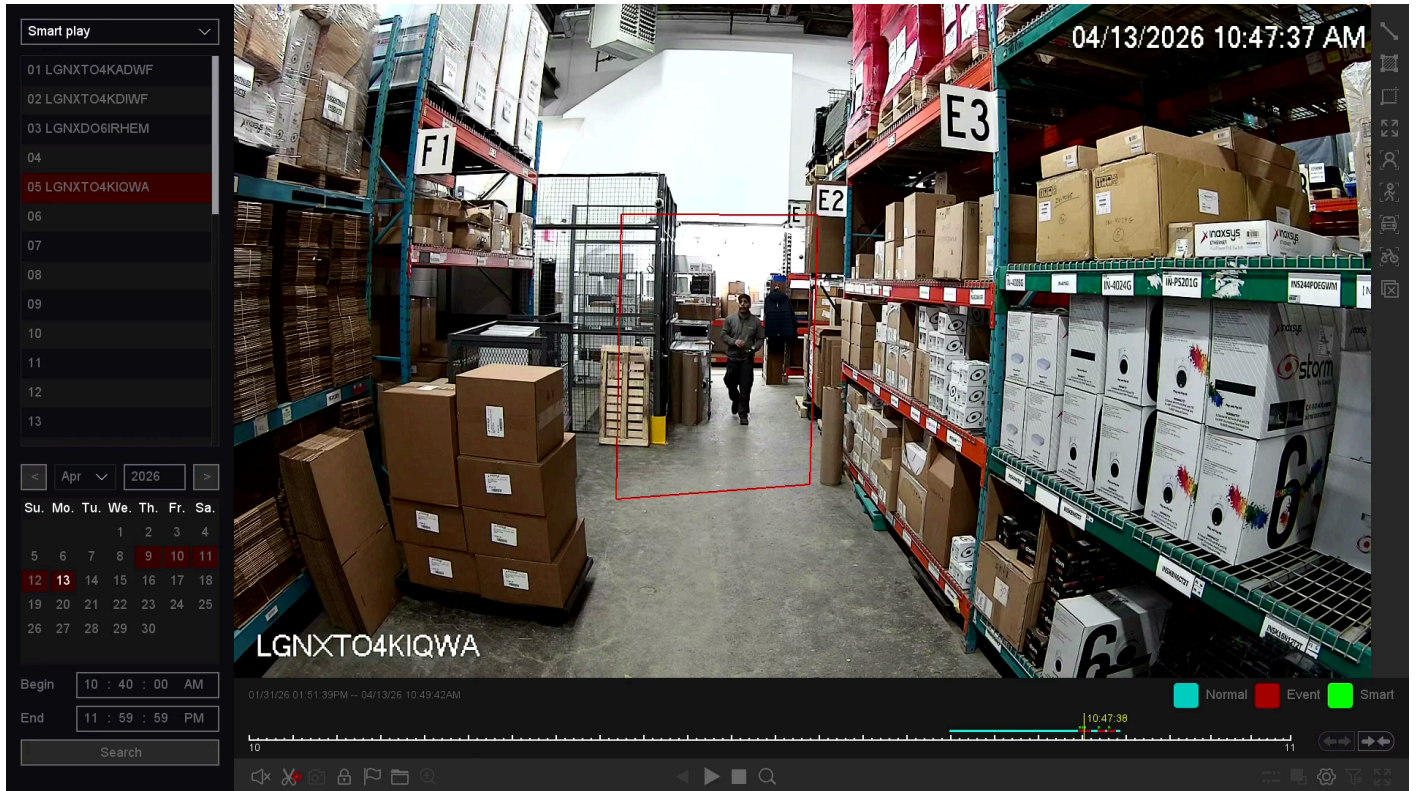

Figure 9-39 Draw Quadrilateral

Motion Draw Rectangle

Steps:



1. Go to **Playback**.
2. Select **Smart Play**.
3. Select the channel and the recording time as required.
4. Click **Play** or click the blue timeline.
5. Click the rectangle  icon to draw an area on the video interface.
6. Click **Setting** to configure the parameters as required.
7. Click **Search**. The results will be displayed below. Videos with Motion events will be marked in **green**, and playback will follow the settings configured in Step 6.



Figure 9-40 Motion Draw Rectangle

Motion Full Screen

Steps:

1. Go to **Playback**.
2. Select **Smart Play**.
3. Select the channel and the recording time as required.
4. Click **Play** or click the blue timeline.
5. Click the full-screen motion  icon to select the entire screen as the detection area.
6. Click **Setting** to configure the parameters as required.
7. Click **Search**. The results will be displayed below. Videos with Motion events will be marked in **green**, and playback will follow the settings configured in Step 6.

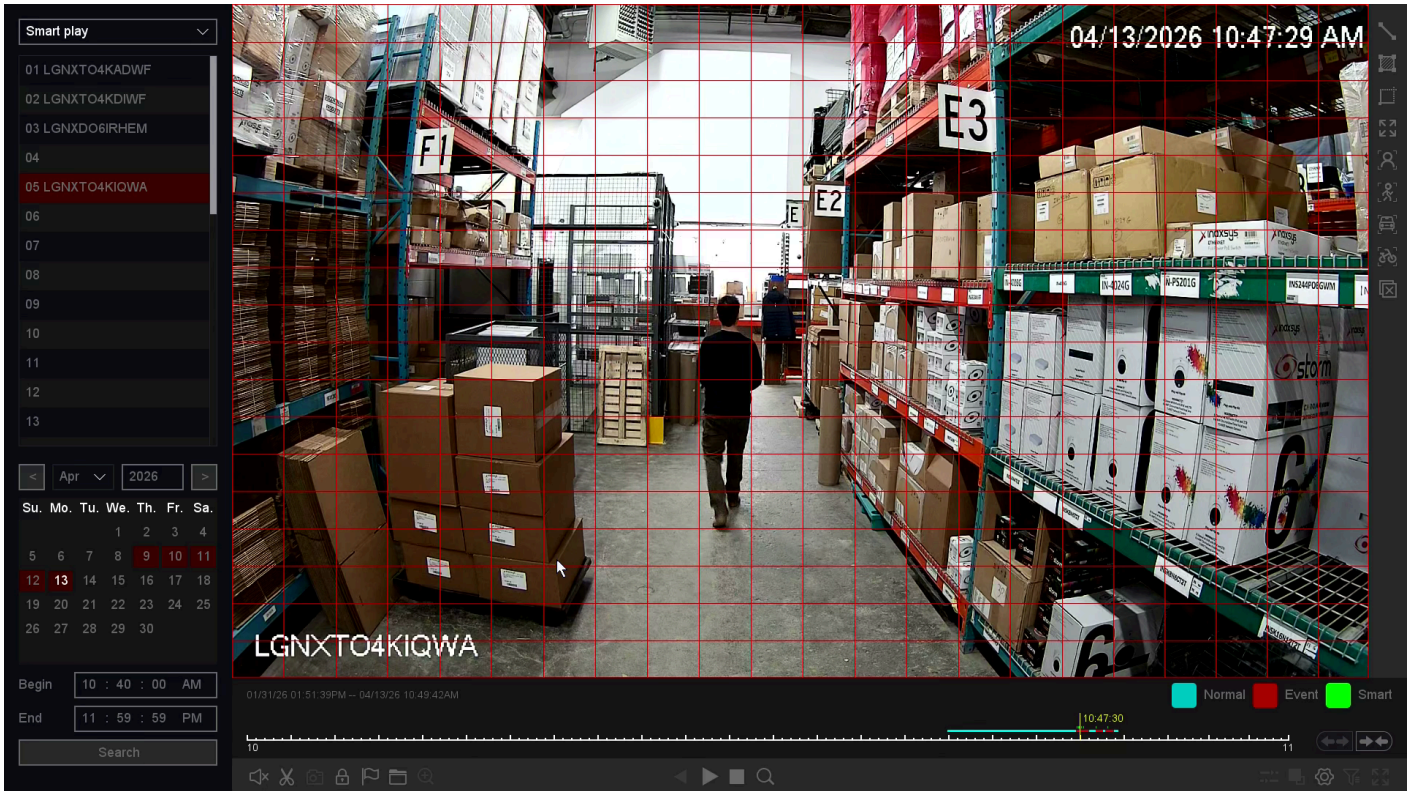

Figure 9-41 Motion Full Screen

9.8.4 Time Division Play

Select **Time Division Play** to enter this mode. On this page, recordings can be played by time period, and the 24-hour recordings are evenly distributed according to the number of windows selected (from 1 to 16 windows).

For example, if 4 windows are selected, the recordings for the chosen date will be divided into 4 segments.

Before You Start

Please ensure that the camera channel has recorded data.

Steps:

1. Go to **Playback**.

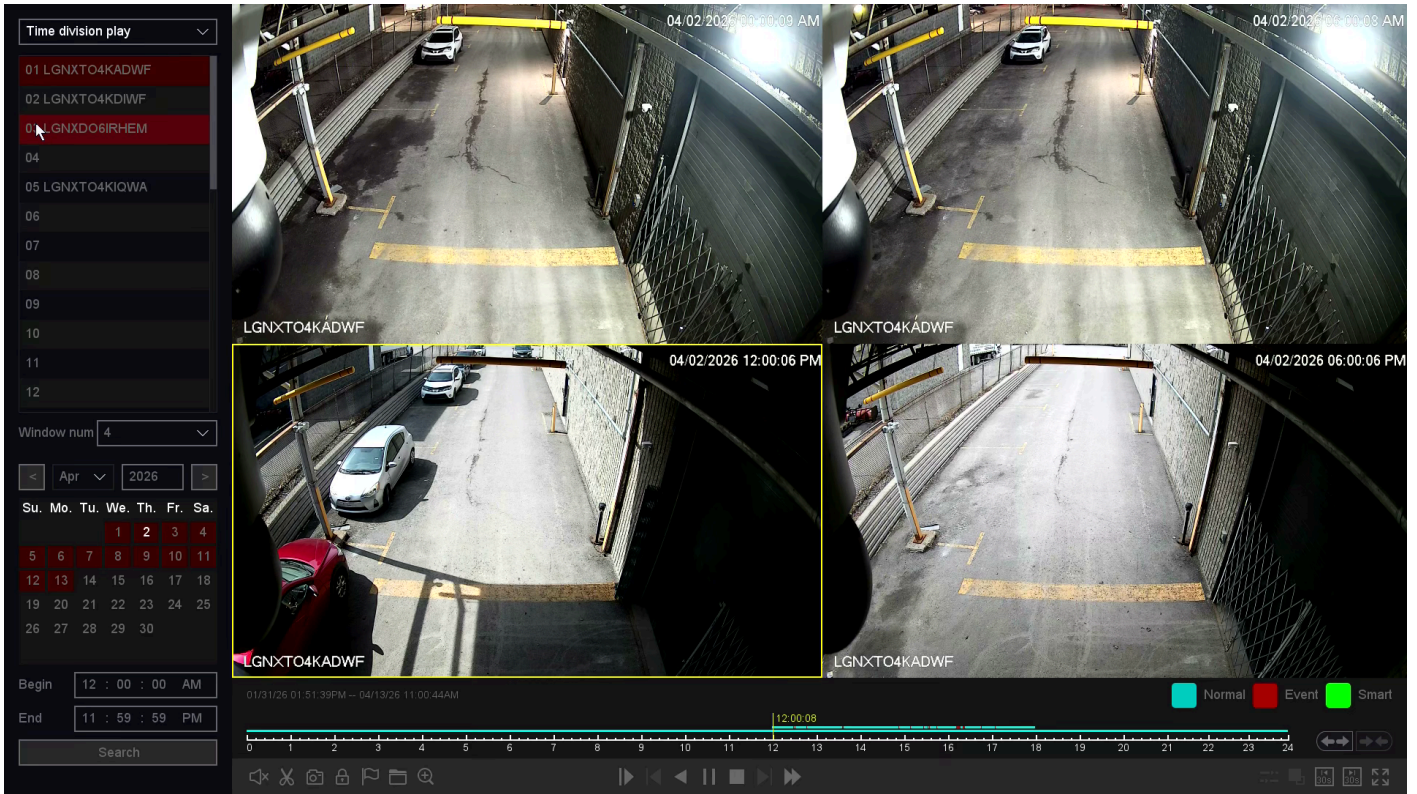

Figure 9-42 Time Division Play

2. Select **Time Division Play**.
3. Select the channel as required.
4. Select the number of division windows and the recording time.
5. Click **Search**.
6. Select the corresponding window to quickly play the desired video segment.

Note

If the number of division windows selected is too large, the device may not be able to decode and display all windows simultaneously. Reduce the number of windows if necessary.

9.8.5 Normal Play (Picture)

On this page, you can play back video in picture format.

Before You Start

Ensure that the selected channel already has images generated by manual capture or by a Perimeter Protection alarm.

1. Go to **Playback**.
2. Select **Normal Play (Picture)**.

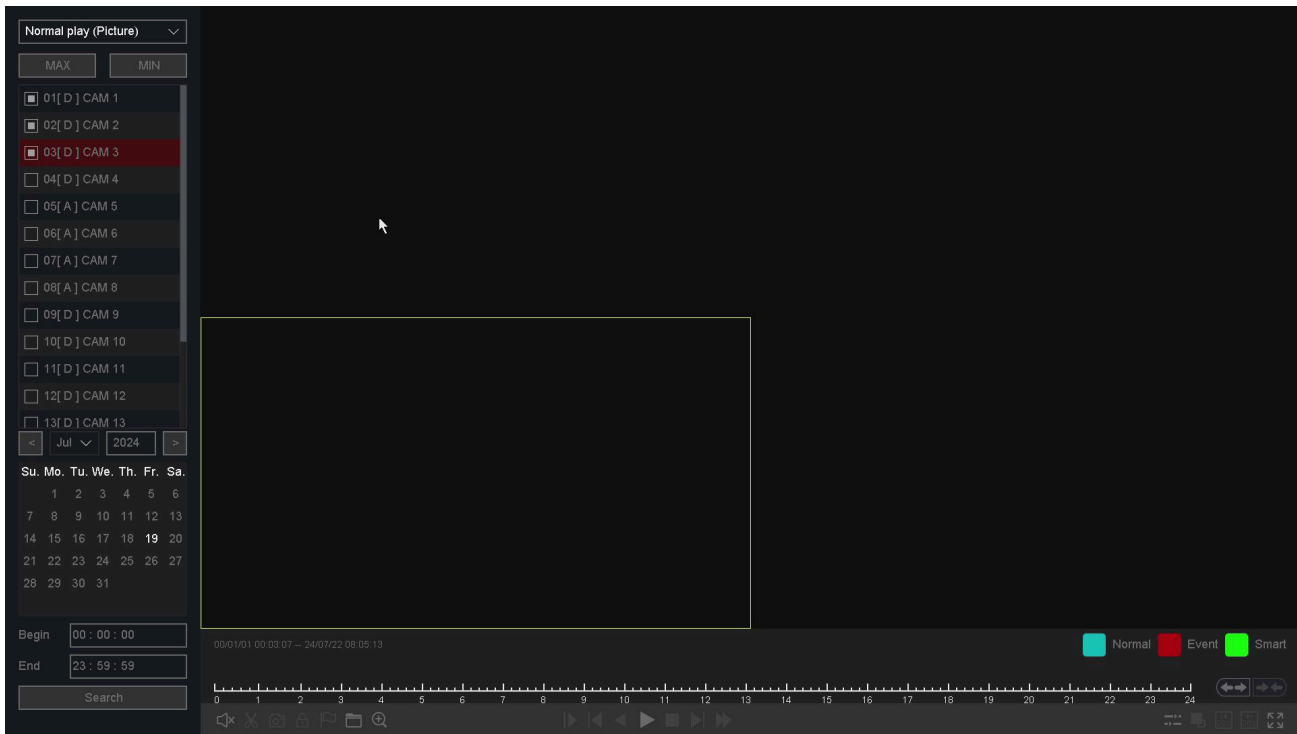

Figure 9-43 Normal Play (Picture)

3. Select the channel as required.
4. Select the time period to play back.
5. Click **Search**.
6. Use the playback control buttons, including **Backup and Retrieval, Zoom, Previous Frame, Start/Pause, Stop, Next Frame, Sync/Async, Full Screen, Slow Down, Speed Up, Timeline Stretch, and Timeline Shorten**.

Note

You can stop playback by right-clicking, and exit the playback interface by continuing to right-click.

10. Web Operation

10.1 Introduction

You can access the video recorder via a web browser.

Supported web browsers include Internet Explorer 6.0 to 11.0, Apple Safari, Mozilla Firefox, and Google Chrome. Supported display resolutions include 1024×768 and above.

10.2 Login

Please note that using this product with Internet access may expose it to network security risks. To prevent network attacks and information leakage, strengthen your security measures. If the product does not function properly, contact your dealer or the nearest service center.

Steps:

1. Open a web browser, enter the IP address of the video recorder, and press **Enter**.

Note

If the HTTP port has been changed, enter <http://IP address:HTTP port> in the address bar.
For example: **http://192.168.1.10:81**

2. Select the language, enter the **User Name** and **Password**, then click **Login**.

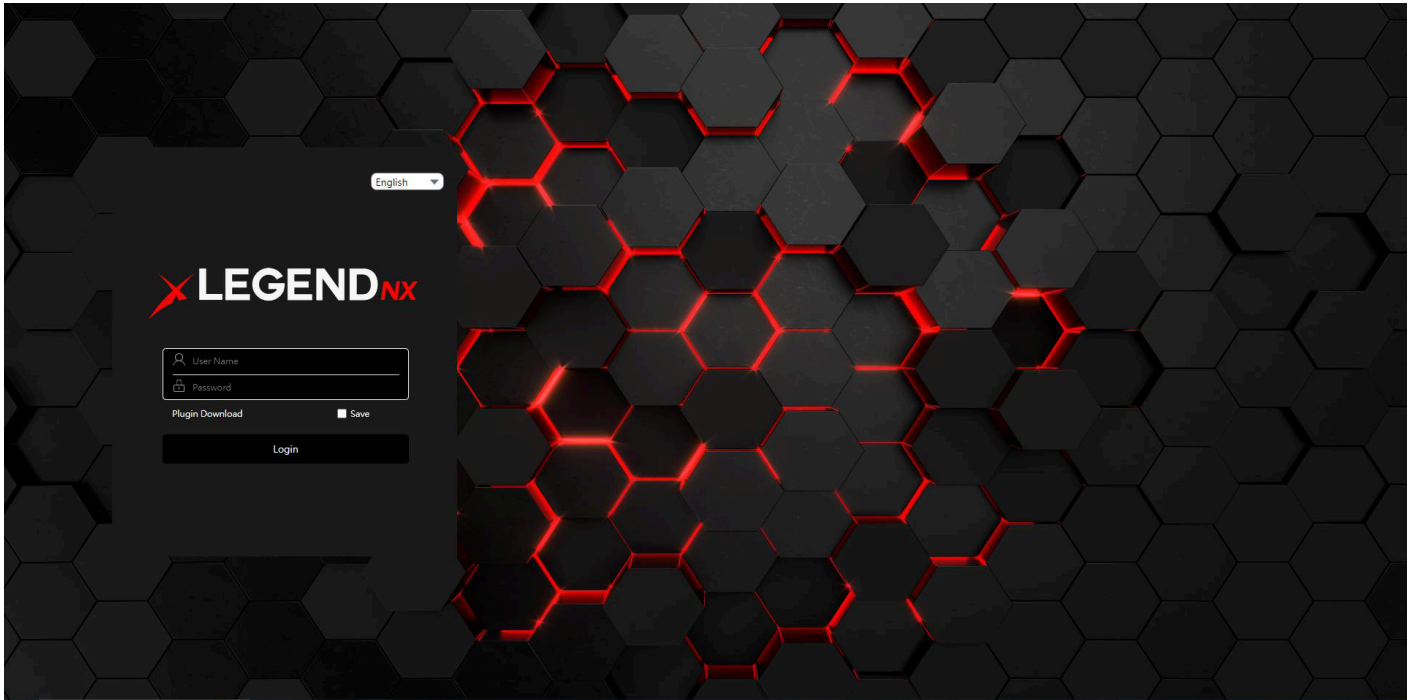

Figure 10-1 Login

3. Follow the on-screen prompts to install the plug-in.

Note

If you log in without installing the plug-in, you will still be prompted to install it. Follow the prompts to complete the installation; otherwise, the system cannot be used properly. You may need to close the web browser to complete the plug-in installation.

10.3 Preview

After logging in, you will enter the preview interface.

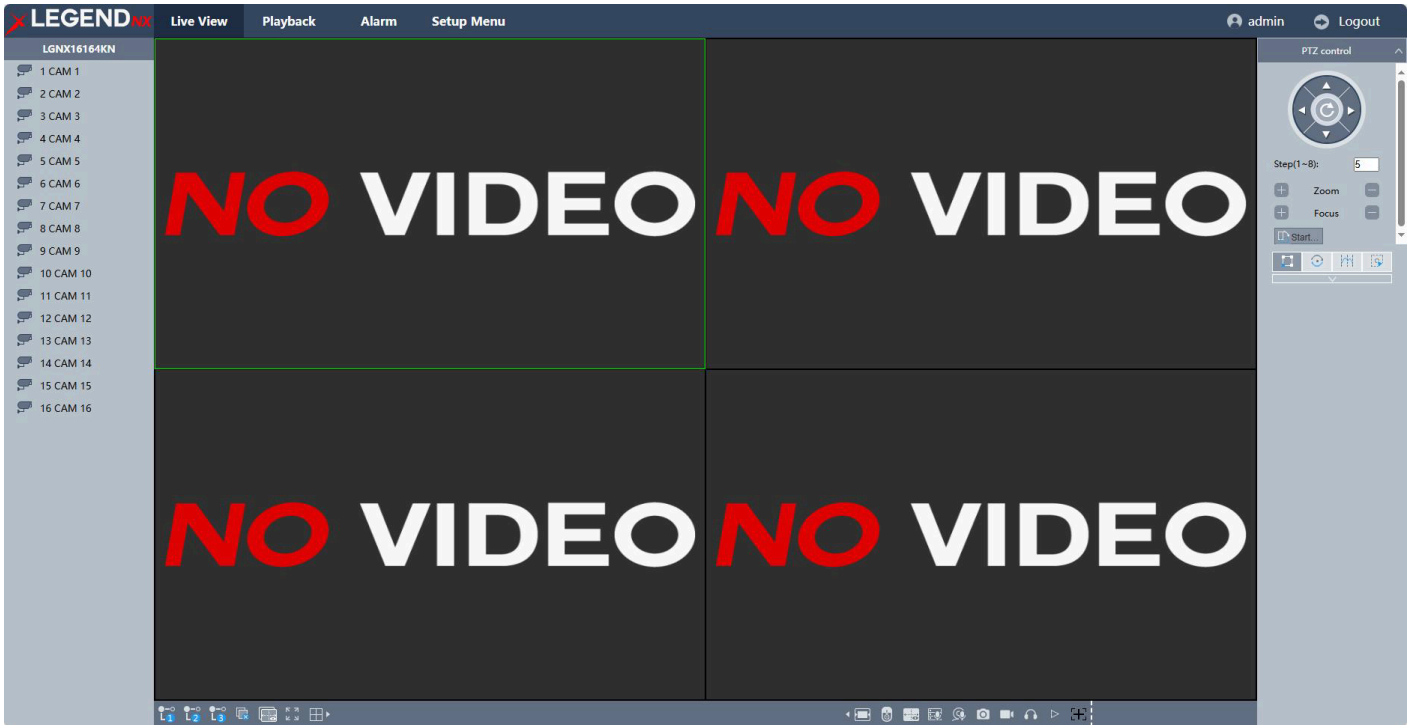

Figure 10-2 Live View

10.4 Playback

Click **Playback** to enter the playback interface.

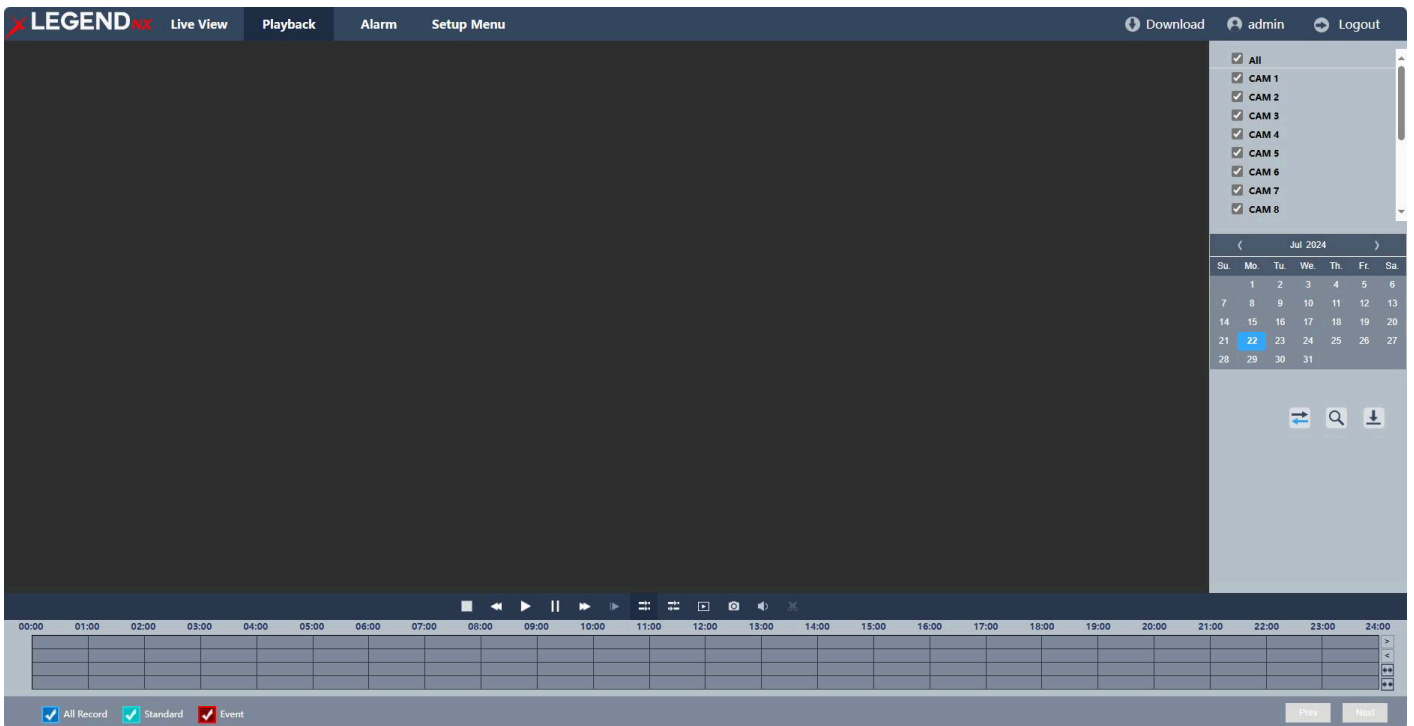

Figure 10-3 Playback

10.5 Set

Click **Set Menu** to enter the configuration interface.

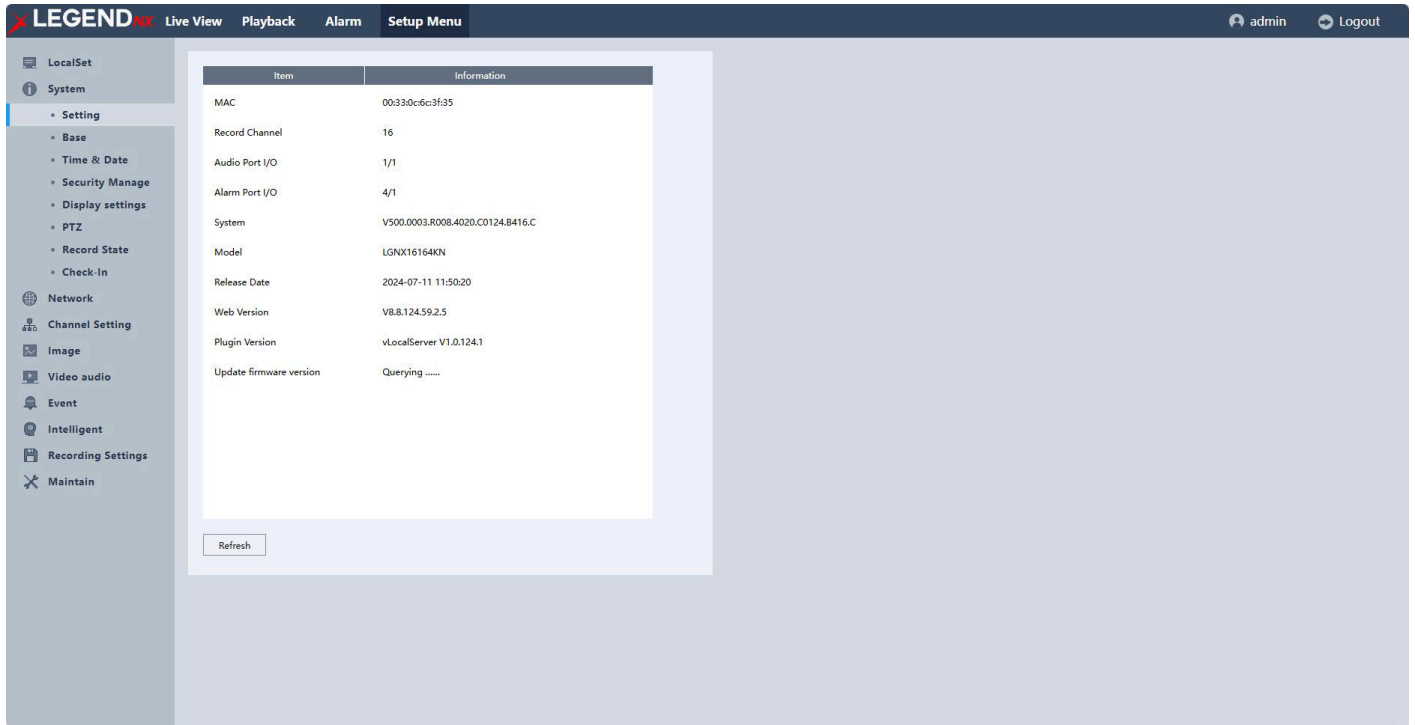

Figure 10-4 Configuration

10.6 Log

Steps:

1. Go to **Set Menu** → **Maintain** → **Log**.
2. Set the search conditions.
3. Click **Search**.

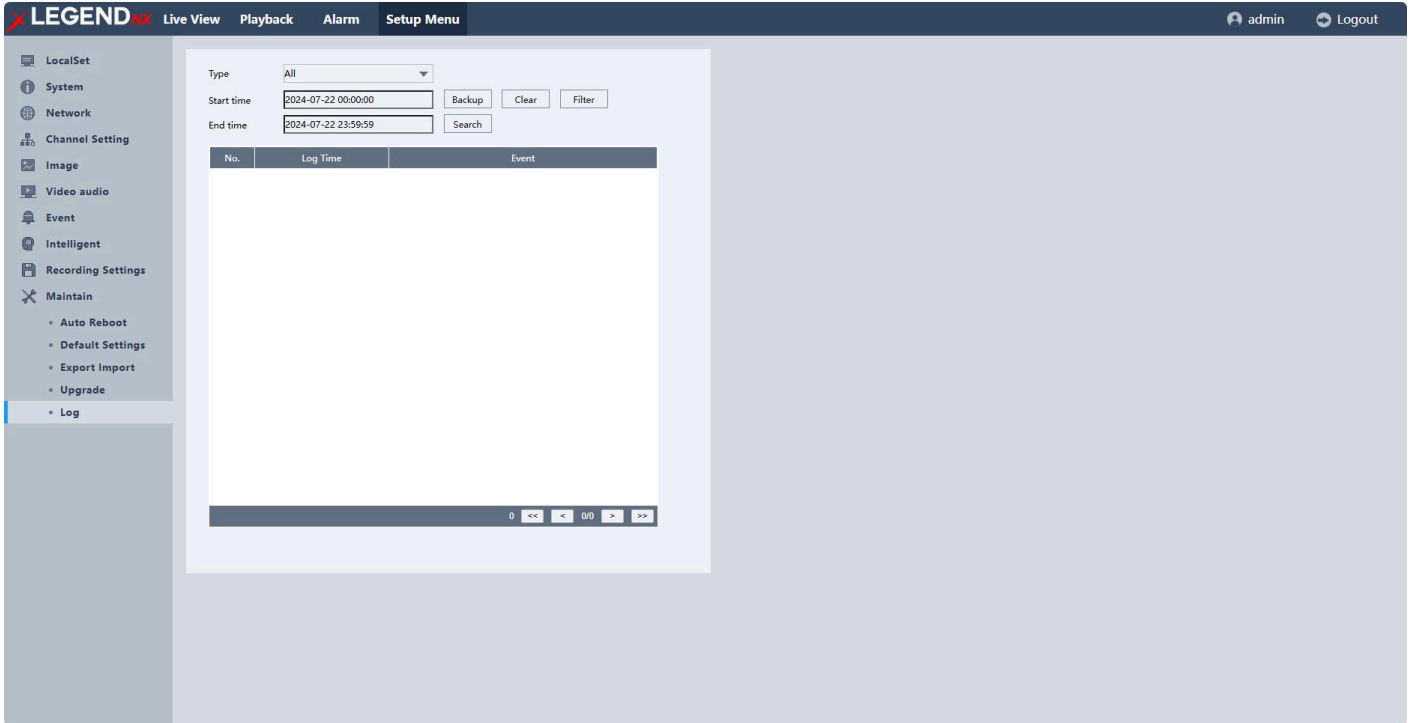

Figure 10-5 Log

11. Appendix

11.1 Glossary

DVR

Acronym for Digital Video Recorder. A DVR is a device that can receive video signals from analog cameras, compress the signal, and store it on its hard drives.

NVR

Acronym for Network Video Recorder. An NVR can be a PC-based or embedded system used for centralized management and storage of IP cameras, IP domes, and other DVRs.

UVR

Acronym for Universal Video Recorder. A UVR can be a PC-based or embedded system used for centralized management and storage of analog cameras, IP domes, and IP cameras.

Dual-Stream

Dual-stream is a technology that records high-resolution video locally while transmitting a lower-resolution stream over the network. The two streams are generated by the DVR, with the main stream supporting up to 4K resolution and the sub-stream supporting up to 720p resolution.

HDD

Acronym for Hard Disk Drive. A storage medium that stores digitally encoded data on platters with magnetic surfaces.

DHCP

Dynamic Host Configuration Protocol (DHCP) is a network application protocol used by devices (DHCP clients) to obtain configuration information for operation on an Internet Protocol network.

HTTP

Acronym for Hypertext Transfer Protocol. A protocol used to transfer hypertext requests and information between servers and browsers over a network.

P2P

P2P, short for peer-to-peer, is a type of computer network often used for distributing digital media files. In a peer-to-peer (P2P) network, each computer acts as both a server and a client—supplying and receiving files—with bandwidth and processing distributed among all members of the network.

DDNS

Dynamic DNS is a method, protocol, or network service that enables a networked device (such as a router or computer system using the Internet Protocol Suite) to notify a domain name server in real time (ad hoc) to update the active DNS configuration of its configured hostnames, addresses, or other information stored in DNS.

NTP

Acronym for Network Time Protocol. A protocol designed to synchronize the clocks of computers over a network.

NTSC

Acronym for National Television System Committee. NTSC is an analog television standard used in countries such as the United States and Japan. Each frame of an NTSC signal contains 525 scan lines at 60 Hz.

PAL

Acronym for Phase Alternating Line. PAL is another video standard used in broadcast television systems in many parts of the world. A PAL signal contains 625 scan lines at 50 Hz.

PTZ

Acronym for Pan, Tilt, Zoom. PTZ cameras are motor-driven systems that allow the camera to pan left and right, tilt up and down, and zoom in and out.

USB

Acronym for Universal Serial Bus. USB is a plug-and-play serial bus standard used to interface devices with a host computer.

Legal Information

© 2024 **Inaxsys Security Systems Inc.** All rights reserved.
Legend NX is a trademark of Inaxsys Security Systems Inc.

About This Manual

This manual provides instructions for the installation, configuration, operation, and maintenance of the product.

All images, diagrams, and illustrations in this manual are provided for reference purposes only and may differ from the actual product. The information contained herein is subject to change without prior notice due to firmware updates or product improvements. For the latest version of this manual, please visit the official Inaxsys website.

This manual is intended for use by qualified professionals. Installation and servicing should be performed by trained personnel only.

Trademarks

Legend NX and all related trademarks, logos, and brand names are the property of **Inaxsys Security Systems Inc.** and may be registered in applicable jurisdictions.

Disclaimer

To the maximum extent permitted by applicable law, this manual and the product described herein, including all hardware, software, and firmware, are provided “**as is**” and “**with all faults.**”

Inaxsys makes no warranties, express or implied, including but not limited to warranties of merchantability, fitness for a particular purpose, or satisfactory quality. Use of the product is at your own risk.

In no event shall Inaxsys be liable for any indirect, incidental, special, or consequential damages, including but not limited to:

- loss of business profits
- business interruption
- loss or corruption of data
- system failure
- loss of documentation

whether arising from breach of contract, tort (including negligence), product liability, or otherwise, even if Inaxsys has been advised of the possibility of such damages.

You acknowledge that internet-based products and systems may be subject to inherent security risks. Inaxsys shall not be held responsible for abnormal operation, privacy breaches, or damages resulting from cyber-attacks, hacking, viruses, or other network-related threats. However, Inaxsys will provide reasonable technical support where applicable.

You agree to use this product in compliance with all applicable laws and regulations. You are solely responsible for ensuring that your use does not infringe upon the rights of third parties, including but not limited to intellectual property rights, privacy rights, and data protection regulations.

This product must not be used for any prohibited purposes, including but not limited to:

- development or production of weapons of mass destruction
- chemical or biological weapons activities
- unsafe nuclear activities or nuclear fuel cycle misuse
- activities that violate human rights

In the event of any conflict between this manual and applicable law, the applicable law shall prevail.

FCC Information

Please note that any changes or modifications not expressly approved by the party responsible for compliance may void the user's authority to operate this equipment.

FCC Compliance

This equipment has been tested and found to comply with the limits for a **Class A digital device**, pursuant to **Part 15 of the FCC Rules**. These limits are designed to provide reasonable protection against harmful interference in a residential installation.

This equipment generates, uses, and can radiate radio frequency energy and, if not installed and used in accordance with the instructions, may cause harmful interference to radio communications. However, there is no guarantee that interference will not occur in a particular installation.

If this equipment does cause harmful interference to radio or television reception, which can be determined by turning the equipment off and on, the user is encouraged to try to correct the interference by one or more of the following measures:

- Reorient or relocate the receiving antenna.
- Increase the separation between the equipment and the receiver.
- Connect the equipment to an outlet on a circuit different from that to which the receiver is connected.
- Consult the dealer or an experienced radio/TV technician for help.

FCC Conditions

This device complies with **Part 15 of the FCC Rules**. Operation is subject to the following two conditions:

1. This device may not cause harmful interference.
2. This device must accept any interference received, including interference that may cause undesired operation.

Safety Instructions

- Proper configuration of all passwords and security settings is the responsibility of the installer and/or end user.
- In the use of this product, you must comply with all applicable electrical safety regulations for your country and region.
- Firmly connect the power plug to the outlet. Do not connect multiple devices to a single power adapter.
Always power off the device before connecting or disconnecting accessories and peripherals.
- **Danger:** Shock hazard. Disconnect all power sources before performing maintenance.
- The equipment must be connected to a properly grounded (earthed) mains outlet.
- The socket outlet should be installed near the equipment and remain easily accessible.
- ⚡ Indicates hazardous live voltage. External wiring connected to terminals must be installed by a qualified person.
- **Warning:** Do not install the equipment in an unstable location. The device may fall, causing serious injury or death.
- The input voltage must comply with **SELV (Safety Extra Low Voltage)** and **LPS (Limited Power Source)** requirements in accordance with **IEC 62368**.
- High leakage current. Ensure proper grounding before connecting to the power supply.
- If smoke, unusual odor, or abnormal noise is detected, immediately power off the device, unplug it, and contact technical support.
- For optimal performance, use the device with a UPS (Uninterruptible Power Supply) and manufacturer-recommended hard drives.
- This product contains a coin/button cell battery. If swallowed, it can cause severe internal burns within two hours and may result in death.
- This equipment is not suitable for use in locations where children are likely to be present.
- Risk of explosion if the battery is replaced with an incorrect type.
- Improper battery replacement may disable safety protections (especially for certain lithium battery types).

- Do not dispose of the battery in a fire or a hot oven. Do not crush, puncture, or cut the battery, as this may result in explosion.
- Do not expose the battery to extremely high temperatures, which may result in explosion or leakage of flammable substances.
- Do not expose the battery to extremely low air pressure, which may result in explosion or leakage of flammable substances.
- Dispose of used batteries in accordance with local regulations.
- Keep body parts away from moving components such as fan blades and motors. Disconnect the power source before servicing.

Preventive and Safety Guidelines

Before installing and operating this device, please review the following guidelines:

- This device is designed for **indoor use only**. Install it in a well-ventilated, dust-free environment away from liquids.
- Ensure the recorder is securely mounted on a rack or stable surface. Dropping or subjecting the unit to strong impacts may damage internal components.
- Do not expose the equipment to dripping or splashing liquids. Do not place objects filled with liquids (such as vases) on top of the device.
- Do not place open flame sources (such as lit candles) on or near the equipment.
- Do not obstruct ventilation openings. Avoid covering the device with materials such as newspapers, cloths, or curtains.
Do not place the device on soft surfaces such as beds, sofas, or rugs that may block airflow.
- Maintain a minimum clearance of **200 mm (7.87 inches)** around the device to ensure proper ventilation.
- For applicable models, ensure correct wiring of terminals when connecting to an AC mains power supply.
- Certain models may be designed or configured for connection to an IT power distribution system. Verify compatibility before installation.
- The battery symbol indicates the battery holder and the correct polarity/positioning of the cell(s).
- The “+” and “–” symbols indicate the positive and negative terminals for direct current (DC) connections.
- Use only power supplies specified in this manual or provided by Inaxsys.
- The USB port is intended for connecting a mouse, keyboard, USB flash drive, or Wi-Fi dongle only.
- Avoid contact with sharp edges or corners of the equipment.

